

**NOTES:**

△ D = DOUBLE SEGMENT  
T = TRIPLE SEGMENT

2. PART NO'S:	SINGLE BULL	DOUBLE BULL	INTERNATIONAL
MERIT #	SW8002	SW8003	SW8010
MERIT/NOMAC#	NSW2301	NSW2302	NSW2303

REVISIONS						
ZONE	LTR	ECN. NO.	DESCRIPTION — SEE. ECN	CHK	DATE	APPROVED
—	0	—	INITIAL RELEASE REV0	—		
—	A	—	UPDATE FOR DOUBLE BULL		8/10/87	JWH

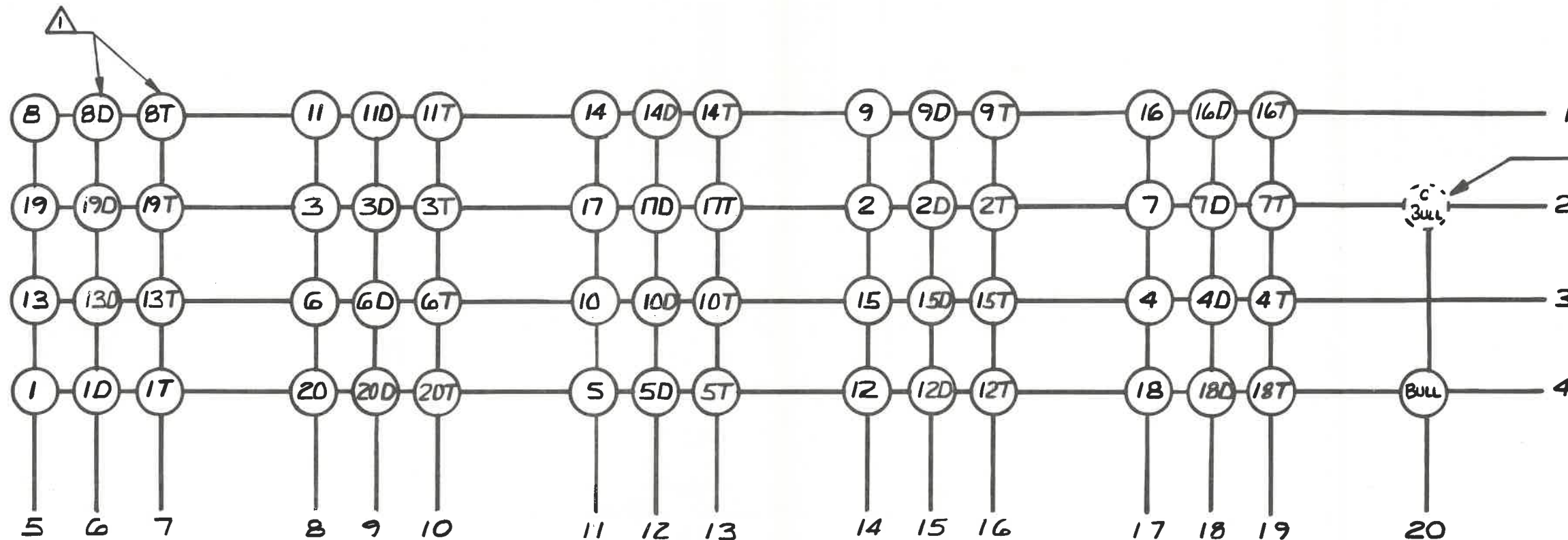

PART NO. SEE NOTES  
IDENT NO.

FOR MAT'L REQUIREMENTS SEE PL.  
PL. REV. LETTER CONTROLS DOCUMENT.

**COMPANY CONFIDENTIAL**

THIS ITEM AND/OR THE INFORMATION CONTAINED THEREIN IS AND REMAINS THE SOLE PROPERTY OF, AND IS PROPRIETARY TO, MERIT INDUSTRIES (MI). THIS ITEM AND/OR INFORMATION SHALL BE KEPT CONFIDENTIAL AND MAY NOT BE REPRODUCED, COPIED, MODIFIED, DISCLOSED, TRANSFERRED, OR MADE AVAILABLE TO OTHERS, EXCEPT WITH THE PRIOR WRITTEN CONSENT OF MI. THIS ITEM AND/OR ALL COPIES, IF ANY, ARE SUBJECT TO RETURN TO MI.

UNLESS OTHERWISE SPECIFIED			LAYOUT	DATE	<b>MERIT INDUSTRIES, INC.</b>		
DIMENSIONS IN INCHES TOL. ON			DRAFTSMAN		TITLE		
2 PLACE DECIMALS	3 PLACE DECIMALS	ANGLES	<i>William A. Kolton</i>	<i>OK</i>	SCHEMATIC		
+	+	+	CHECKER		MERIT / NOMAC		
SURFACE FINISH NOT TO EXCEED 125 REMOVE BURRS & SHARP EDGES			ENGINEER	8/19/86	SWITCH TARGET MATRIX		
MATERIAL:			APPROVAL	8-19-86	SIZE	CODE IDENT NO.	DWG NO.
THREADS: EXT. CL 2A, INT CL 2B					B		2500/0027
COMMODITY CODE					SCALE	WEIGHT	SHEET 1 OF 1

DWG. NO. 2500/0027