



# COIN MECHANISMS INC.

*Where The Money Meets The Machine*

PO Box 5128, 400 Regency Drive, Glendale Heights, IL 60139 FAX: (630) 924-7088 VOICE: (630) 924-7070

## USER MANUAL DEFENDER TESTER P/N 00660013 09300349 REV. 0 3/9/2004

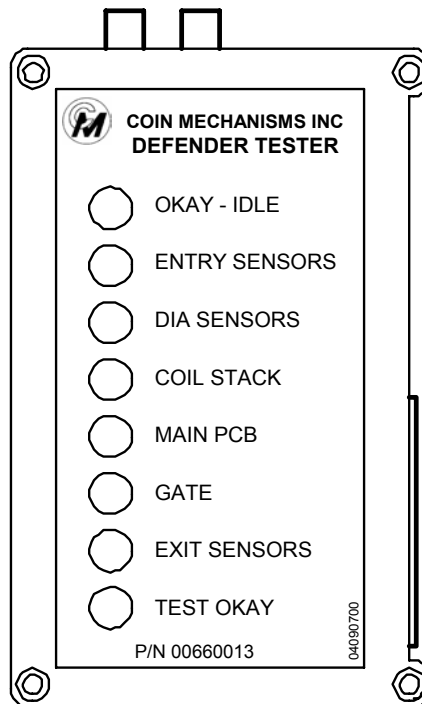

### OVERVIEW

The **Defender Tester** is designed to test and troubleshoot the Defender down to the sub-assembly level using LED indicators. It is an optional accessory to the new (00660011) Test Station. If the Defender has been properly calibrated using the Test Station, and does not accept coins, use the **Defender Tester** to determine what sub-assembly may have failed. This manual will walk the technician through the operation of the **Defender Tester** and how to determine what sub-assembly may have failed so that it can be replaced.

## **EQUIPMENT**

The **Defender Tester** is comprised of the following:

<b>PART NUMBER</b>	<b>DESCRIPTION</b>
00660013	DEFENDER TESTER UNIT
0928-000163	I/F,ASM,DEFENDER TESTER TO DEFENDER TEST HEADER
0928-000164	I/F,ASM,TEST STATION TO DEFENDER TESTER

## **DISPLAY FUNCTIONS**

The Defender Tester uses a series of LEDs to indicate the failed component on the Defender product. The “OKAY - IDLE” and “TEST OKAY” LEDs are Green. The “ENTRY SENSORS”, “DIA SENSORS”, “COIL STACK”, “MAIN PCB”, “GATE” and “EXIT SENSOR” LEDs are Red. The Green LEDs indicate that the product is operating correctly. If any of the Red LEDs light, the sub-assembly associated with that LED needs to be replaced.

## **I/O HOOKUP FUNCTIONS**

Connect 0928-000164 from JP3 of the Test Station to the seven pin Molex connector on the Defender Tester. Connect the 0928-000163 from the 12 pin JST connector on the Defender Tester to the 12 pin Molex Test Header on the Defender main circuit board.

Refer to the Specification Sheet for each specific Defender part number to determine the proper Customer Interface Assembly required. Defender specification sheets are available at the web site – [www.coinmech.com](http://www.coinmech.com)).

## **PRELIMINARY SETUP:**

1. Connect the Defender customer connector to JP2 of the Test Station using the appropriate interface (see the specification sheet for each Defender part number).
2. Connect the Defender tester to JP3 of the Test Station using the 0928-000164 interface.
3. Connect the Defender tester to the Defender test header using the 0928-000163 interface.
4. Install a sample coin into the resident coin location of the Sensor Coil assembly.
5. IMPORTANT: TURN THE POTENTIOMETER TO FULL CLOCKWISE BEFORE TESTING.
6. Apply power to the Defender. On the Test Station switch the “MECH POWER” to on. Power will also be applied to the **Defender Tester** at the same time. Verify that the LEDs on the Defender and **Defender Tester** are lit.

## **DEFENDER TESTER OPERATION**

1. If the LED on the Defender is Green when power is applied, then the “OKAY – IDLE” LED should light on the **Defender Tester**. This indicates that no failures are detected in the idle state.
2. If the “OKAY – IDLE” LED is lit, drop a test coin through the mech that matches the sample coin. If the coin is accepted, “TEST OKAY” LED on the **Defender Tester** will light. This indicates that **no** failure is detected.
3. If the coin is rejected, a Red LED associated with the failed sub-assembly will light and the Defender LED will turn Red. (see troubleshooting section)
4. If the LED on the Defender is Red when power is applied, a Red LED on the **Defender Tester** associated with the failed sub-assembly will light. (see troubleshooting section)

**NOTE:** If the coin was rejected but the Defender LED remained Green, verify the potentiometer position. If the coin is rejected because the pot is set to a very sensitive position, the Defender LED will remain Green and the Defender tester will indicate the “COIL STACK” is bad. Readjust the pot to the full clockwise position and drop the coin again. If the coin is still rejected, the Defender LED stays Green and the **Defender Tester** indicates a bad “COIL STACK”, try dropping a different coin from the same population of coins.

## **TROUBLESHOOTING**

This section identifies the possible failed sub-assemblies indicated by each Red LED on the **Defender Tester**. There is more than sub-assembly associated to each failure type (eg. if the Entry Sensors LED is lit, the failure could either be the Entry Sensor pcb or the Main pcb).

The bullet points listed below each Red LED failure indicator heading are in order of highest chance of failure. (eg. if the Entry Sensor LED is lit, it is more likely that the Entry Sensor pcb has failed. If the Entry Sensor pcb is replaced with a known good replacement and the Entry Sensor LED still lights after re-testing, then replace the Main pcb).



### **ENTRY SENSORS**

- Replace 06270048 Entry Sensor pcb
- Replace 0927-000570 Main pcb



### **DIA SENSORS**

- Replace 06270048 Entry Sensor pcb
- Replace 06270054 Rail Optic pcb
- Replace 0927-000570 Main pcb

● COIL STACK

- Replace complete Coil Stack assembly (See table below for correct assembly part number). The figure below shows where to find the “#2 Defender Coil Number” location.

#2 Defender Coil Number	Coil Stack Assembly
9250111	06250351
9250123	06250350
9250124	06250352

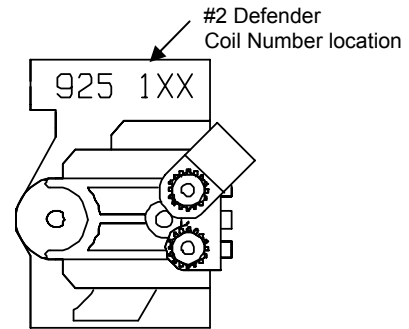

● MAIN PCB

- Replace 0927-000570 Main pcb

● GATE

- Replace 06250225 COIL&BRT,ASSY,GRN
- Replace 0927-000570 Main pcb

● EXIT SENSORS

- Replace 06270049 Exit Sensor pcb
- Replace 0927-000570 Main pcb