

~~~~~  
~~~~~  
~~~~~  
~ Owners Manual for NATO DEFENSE ~  
~~~~~  
~~~~~  
~~~~~

Pacific Novelty Manufacturing
Customer Service Department
4094 Glencoe Avenue
Marina Del Rey, Ca. 90291
(213) 822-0399

* No part of this document may be reproduced or disclosed
except with the prior written approval of PNM *

(PL062182)

INDEX

PART I	-	QUICK REFERENCE CHART OF SETTINGS
PART II	-	OPERATIONS MANUAL
PART III	-	DIAGNOSTICS
PART IV	-	NOTICES

 TOP LEFT DIP SWITCH

1 2

0 0	10,000 POINTS / BONUS TANK	SOFTWARE VERSION:
1 0	20,000 POINTS / BONUS TANK	062182
0 1	30,000 POINTS / BONUS TANK	
1 1	40,000 POINTS / BONUS TANK	

SWITCH 3 - ON = Disable Sound Demonstration in Attract mode

OFF = Enable Sound Demonstration in Attract mode

SWITCH 4 - ON = BONUS TANK FOR SCORES ABOVE

OFF = NO BONUS TANK FOR ANY SCORE

5 6 7 8 <- SWITCH NUMBERS

0 0 0 1 - BURN-IN TEST(1ST 2 DIGITS IN CHECKSUM=SOCKET#)

1 0 0 1 - COLOR BAR DISPLAY

0 1 0 1 - CROSS HATCH GRID

1 1 0 1 - CONTINUOUS COLOR MAP WRITES

0 0 1 1 - VIDEO RAM ADDRESS SELECT WRITES

1 0 1 1 - VIDEO BIT MOVE

0 1 1 1 - IO BOARD DRIVER TEST

1 1 1 0 - Display current options in effect

*** Close SLAM switch or turn off/on game for new test ***

*** DON'T FORGET TO TURN OFF 5,6,7 & 8 WHEN DONE!!!!!! ***

 TOP RIGHT DIP SWITCH

1 2

5 6

0 0	25 CENTS/GAME	0 0	EASY (LIBERAL)
1 0	50 CENTS/GAME	1 0	MEDIUM EASY
0 1	2 games/25 cents	0 1	MEDIUM HARD
1 1	1 game/25 3 games/50	1 1	HARD (CONSERVATIVE)

3 4

0 0	3 TANKS/GAME	SWITCH 7	if on then cocktail version
1 0	4 TANKS/GAME		if off then upright version
0 1	5 TANKS/GAME		
1 1	7 TANKS/GAME	SWITCH 8	if on then Add-A-Coin feature enabled.
			if off then no Add-A-Coin

 SYMBOLS: X <-IGNORE ; 1 <-TURN ON (CLOSE) ; 0 <- TURN OFF (OPEN)

Your NATO DEFENSE game incorporates a number of adjustments in order to control the time the player can tie up the machine. You can control the followings:

1. Number of tanks per game 3,4,5 or 7 tanks.
We suggest 3 tanks per game
2. Bonus tank feature - at a selected score level
We suggest you turn this feature on
3. Points needed for bonus tank.
We suggest 10,000 points per bonus tank
You can set it at 20,000 , 30,000 or 40,000 points.
4. Price per play.
We suggest you follow your location policy as to price.
you can select 25 or 50 cent play.

Controls used in the Game

The Player has the following controls:

Joystick - When moved in any of four directions, the player's tank will move in that direction. That is up, down, left, right. The Joystick contains four switches which are depressed by the movement of the control by the player.

One Player Start - Starts the single player game if an appropriate number of coins have been deposited.

Two Player Start - Starts the two player game if an appropriate number of coins have been deposited.

Hardware Concepts

The same is composed of two circuit boards:

1. Processor board - Contains,
 - A. Microprocessor
 - B. Memories (RAM & ROM)
 - C. Video Generator
 - D. Control Logic
2. Interface Board - Contains,
 - A. Sound synthesizers
 - B. Switch input decoding
 - C. Option DIP switches
3. Coprocessor Board -
 - A. Proprietary logic to increase performance of Z80 for graphics functions.

The Processor board acts as the brains and display unit for the game. It contains a Z80 microprocessor and Read Only memories which contain the programming for the game. In addition the board contains the hardware for generating the color display seen by the player on the monitor. The control logic incorporated in the same allows for peripheral boards (Interface board) to communicate with the microprocessor.

A computer would not be of much use to anybody unless it could talk to 'the outside world'. The Interface Board serves this purpose. The boards acts as the 'eyes and ears' of the computer - scanning coin, start, joystick and other switch inputs and reporting their status to the computer. In addition to having 'eyes and ears' a game needs a mouth - sound. The board also serves as the generator of synthesized sounds via it's two PSG (programmable sound generators) and amplifiers. This game also incorporates a tape unit which supplies special sound effects. The board serves to control the following functions:

- 1: Supply power to tape Unit (Transistor switch).
- 2: Connect left channel to speaker (relay contacts).
- 3: Connect right channel to speaker (relay contacts).

The tape unit is an automotive type stereo unit which contains an cassette recorded by PNM. The Interface Unit takes care of all the needs of the recorder, turning it on and off and 'cueing' the individual tracks to the outside world as required.

Game Set-Up on Location

Before placing the game on location you may want to reconfigure the game to suit the clients in your location.

To set up the sound, first start the game in the two player mode and then adjust Channels A,B and C. To adjust Channel D you will need to have someone play the game while you fiddle with the tape unit controls.

Sound -

The game incorporates four channels of sound. You may want to change the volumes of these channels - this is how you do it.

Channel A - (PSG) Warning tone: Adjust trimmer pot on interface board (Small Board hooked to large board) at

Location -> 7D

Channel B - (PSG) Mine explosion sound trimmer pot on interface board (Small Board hooked to large board) at

Location -> 7C

Channel C - Tank chatter sound coming from tape unit. On tape unit itself. Control the Master volume for Channels C and D by increasing the 'VOLUME' control on the tape unit itself. To make Channel C louder than D move 'BALANCE' control till the desired volume is obtained.

Channel D - Tank crash sound coming from tape unit. On tape unit itself. Control the Master volume for Channels C and D by increasing the 'VOLUME' control on the tape unit itself. To make Channel D louder than C move 'BALANCE' control till the desired volume is obtained.

Helpful Hints about your Game

There are a number of areas you should pay attention to in order to maximize your earnings from this game.

Care of the Color Monitor-

The primary display device for this game is the Color Monitor. When you receive your game, or move it around, you may find that the game has acquired what appears to be a case of multi-colored blotchy color areas. These are caused by stray magnetic fields which magnetize the tube and surrounding metal. We suggest that you 'desauss' your game with a desaussing coil. The coil is a large round electromagnet which plugs into the 110 volt line. Since the power line is AC it has the property of demagnetizing the parts near and on the monitor. Your distributor most likely has such a coil and will be able to instruct you in its use (if you need it at all). All controls on the monitor have been preset at the factory. If you change any of the controls you better know what you are doing!

Care of Tape Unit-

This game incorporates an leaderless autoreverse cassette which produces the chatter between tanks as well as the crashing sounds when the tanks are hit. We suggest that you pay particular attention to the maintenance of this unit. If you find that the Stereo unit is functional (try playing a regular tape in it), yet the leaderless cassette doesn't play, you may have a damaged or worn out tape (under normal use (?) these tapes have a lifetime of over two(2) years). You may purchase from PNM, a replacement for your original tape.

Care of Player Controls-

The pushbutton parts used in the front panel of the game can be directly cross-referenced to WICO replacements. The leaf switches are gold plated and may be cleaned with an ordinary piece of paper rubbed between the two surfaces. An ordinary point adjusted may be used to set the spacing. The Joystick should be aligned so that it is sensitive for deflection in 4 directions.

Coin Door -

The list of things that can be done to a coin door is unbelievable. If the mech fails to accept coins after months of service we suggest you clean it (Who's buried in Grant's Tomb?). The door incorporated a slam switch which is NORMALLY OPEN. To test the operation, kick the door and watch for a game reset. The slam switch erases ALL credits (sorry Charlie!).

Cabinet Levelers -

The cabinet is shipped with levelers used to make the game level (logical?). We strongly suggest that you install them to: A. Protect your floors from scratching; and B. To keep your players from waltzing your game across the floor.

TLC -

Treat your game with a lot of care and it will make bags and bags of quarters for you. Here at the factory we put a lot of care into the programming and building of the game to make the game a success. Keep the game working in top form and both you and the players will be happy cookies.

DIAGNOSTICS SECTION III

DIAGNOSTICS SECTION III

```

*****
*****
*****
*****
***** *   DIAGNOSTIC   TEST   * *****
*****
***** * PACIFIC NOVELTY MANUFACTURING *****
*****
*****
*****
*****
*****
*****

```

The Rom test set supplied allows the technician to test the electronics package in the NATO DEFENSE game.

-
1. DIAGNOSTICS ARE ENABLED WHEN SWITCH 8 IS ON -
(THE BOTTOM MOST AND LEFT SWITCH).
 2. CLOSE SLAM SWITCH TO SIGNAL CHANGE OF DIAGNOSTICS SWITCH
-

```

1 2 3 4 5 6 7 8 <- SWITCH NUMBERS
X X X X 0 0 0 1 - BURN-IN TEST(1ST 2 DIGITS IN CHECKSUM=SOCKET#)
X X X X 1 0 0 1 - COLOR BAR DISPLAY
X X X X 0 1 0 1 - CROSS HATCH GRID
X X X X 1 1 0 1 - CONTINUOUS COLOR MAP WRITES
X X X X 0 0 1 1 - VIDEO RAM ADDRESS SELECT WRITES
X X X X 1 0 1 1 - VIDEO BIT MOVE
X X X X 0 1 1 1 - IO BOARD DRIVER TEST
X X X X 1 1 1 1 - (RESERVED FOR FUTURE USE)          (SETTINGS)

```

DIAGNOSTICS SECTION III

BURN-IN Test Rom instructions

The Burn in test supplied to you contains the following tests:

- 1: Checksum of all roms in the system -
Reports the condition of all ROMS on board.
- 2: Harness/Control/IO board Test sequence
Displays the position of all switches in the system.
- 3: Dip Switch Display
Shows the switch positions of the two dip switches on the IO board.
- 4: 2114 RAM test - Test the condition of the on board RAM.
- 5: 4116 RAM test - Test the display RAM.
- 6: Coprocessor test - Test verious section of coprocessor

DIAGNOSTICS SECTION III

* TYPICAL DISPLAY *

06/21/82 <- Version of this ROM set

```

<Cpu Checksums>      <Cop Checksums>
00    <ok>            B4=<ok>      <- Coprocessor EPROM test
02    <ok>            C4=<ok>
04    <ok>            D4=<ok>
06    <ok>            H4=<ok>
08    <ok>            J4=<ok>
10    <ok>            K4=<ok>
12    <ok>
14    <ok>

```

(Cocktail version)

```

. . . .
. . . .      <- These are the Dip Switches
. . . .      <- . . . Open circuit __ Closed circuit
. . . .
. . . .      2114 ERR    <- Bad 2114
. . . .      4116 ERR    <- Bad 4116
. . . .

```

(Player 1 control) (Player 2 control)



^ 1 2 player start
 Either fire button

Note that from time to time you may get a 4116 error message. Since the 4116 ic's are used in the video section, you can still have a very playable game with a small fraction of errors.

If you get any error messages in the lower left side of the screen, these are caused by problems with the Coprocessor board. Errors such as 'CNTXT ERR' or 'ADDR XLAT ERR' are Coprocessor generated. If you receive a large number of messages in the lower left hand side, you either have the power missing from the corocessor or else the 50 pin flat cable has come loose.

All errors besides 4116 are of a very serious nature and should be corrected immediately as they impair the earnings of the game.

DIAGNOSTICS SECTION III

!!!!!!!!!!!!!!!!!!!!
!!!! CAUTIONS !!!!
!!!!!!!!!!!!!!!!!!!!

There are a number of dependences and limitations of this particular test rom.

1. The whole relam of tests depend on the existence of GOOD RAM in the lowest 1k sesement of memory.

2. The tests used for the detection of errors and the 2114 and 4116 tests are very limited in their scope and the ability to trace down subtle problems in these areas.

CHECKSUMS

The first test (checksums) adds up the contents (numbers in ROM) and generates a checksum number. The Test Rom has a table of correct values and upon finding the correct value displays '<ok>' to indicate it found what it expected. In case it doesn't find the correct number it will display a four digit number (16 bit hexadecimal checksum found). In case you do get something other than the '<ok>' check you manual for any changes which may have been made to that rom since the production of the test rom.

DIP SWITCHES

The Dip switch display provides you with a method of determining the position of the dip switches located on the IO (small) board. What you are seeing on the screen is the internal representation (as the computer sees them) of the dip switches on the IO board. This test is useful in determining the most low level operation of the IO board.

PLAYER CONTROL DISPLAY

One thing that is most annoying is problems in the harness and the adjustment of switches. This test shows you the opening and closing of switches on the:

- A: Player 1 control panel
- B: Player 2 control panel
- C: Coin and slam switches
- D: Fire button

The dots (.) shown represent the identical switches and their correct positions on the front panel of the actual game. The only exception to this rule is on the Player 2 panel. In this case you will find that the positions used for the one and two player start have been replaced with the COIN and SLAM switches. The symbols (.) and (*) represent the OPEN and CLOSED positions of the switches on the front panel.

Theory of Operation

Imbedded in the base of the ROM0 rom is code which detects the existence of a Rom14. If it does find a rom in this position it checks for the proper contents at the beginning of the ROM14 and if they are correct, the system begins execution at beginning of ROM14 + 6.

DIAGNOSTICS SECTION III

COLBAR - Color Bar display generator.

THIS routine generates a color bar pattern to test the operation of the video section. The test itself erases a byte to zero then writes to the selected plane of display memory.

You will find this routine especially useful for testing the Wait line back to the CPU as well as the timing of writes.

The following must be running for this test to operate:

- 1 CPU and select logic to RAM/ROM
- 2 CPU RAM

DIAGNOSTICS SECTION III

VIDSEL - Video Ram select writes

In this test we cause each of the Video RAM select lines to be selected. Each Video RAM is read and written to in sequence. This test is designed to check that the Video section is actually connected to the CPU section.

Use this test to check for the existence of /MRD + /MWR +/WAIT as well as the address lines leading to the Video RAMS and the signals internal to the video circuit. Each address line going to the Video RAMS is exercised as well. In addition the data written is incremented after each pass through the test.

The test will try to reset the Video Controller chip and then begin to read and write data to each of the address boundary location points 1,2,4...last significant address. These are the only locations which will be written to.

Sync your scope to the /OUT 0 select as this signals the start of a select sequence.

DIAGNOSTICS SECTION III

VIDBIT - Video bit Move

This routine generates a single bit write in each and every cell (byte) in the display memory. It is intended to detect stuck bits in individual planes.

In the normal operation of this routine, you will see thirty two lines across the screen. On each pass you will see the entire group move to the side one single cell. You will notice that the test repeats after every eight writes due to there being only eight bits to test per cell.

Since the memory is arranged to the processor as eight bit bytes and the internal representation is as 4 bit pixels. You may be able to isolate the problem to whether the problem is of a 4 or 8 bit error pattern. - Internal to video or in the interface between the two.

This test requires that the CPU be functioning as well as the 2114 Ram section. Selects to these sections must of course be operating.

DIAGNOSTICS SECTION III

PSGTST - IO board driver test

Programmable sound generator and OUTPUT DRIVER test

In the Pss test, each channel of the pss is, in sequence frequency modulated at full volume.

After all the Pss's have been tested, the relays and transistor drivers are sequenced in order.

Sequence:

- 1 All units off
- 2 Tape power on
Talk track on
Coin meter power on
- 3 Explosion track relay on
- 4 Explosion track relay off
Coin meter off
Talking track relay off
- 5 Start at sequence number 1 again

While each of the above is going on, each of the 6 channels of the PSG's (3 channels per PSG) is being frequency modulated. This makes a sort of Whooop, Whooop, Whooop and pause sound. The frequency modulated sequence is carried out on the total of 6 channels supplied by the two PSG's.

NOTICES IV

WARRANTY

Pacific Novelty Manufacturing (PNM) warrants that it's circuit boards and parts are free from any defects in workmanship and materials under normal use and service, for a period of thirty (30) days from date of shipment. PNM also warrants it's television monitors (in games which use them) to be free from any defects in workmanship and materials under normal use and service, for a period of Thirty (30) days from date of shipment. No other of the Seller's products or parts therefor are warranted.

If the product described in this manual should fail to conform to this warranty, The seller's sole liability shall be, at its option, to repair, replace, or credit Buyer's account for such products which are returned to the Seller during the said warranty period provided that:

A) The Seller is promptly notified IN WRITING upon discovery by the Buyer, that said products are defective.

B) Such products are returned to the Seller's plant; and

C) Seller's examination of the said products discloses to the Seller's satisfaction that such alleged defects existed and were not caused by alteration, improper repair, installation, accident, misuse, improper testing or accident.

In NO event shall Seller be liable for incidental or consequential damages such as loss of profits, loss of use or any other such losses.

Except for any express warranty set forth in written contract between Seller and Buyer which contract supersedes the terms of this order, this warranty is expressed in lieu of all other warranties expressed or implied, including the implied warranties of merchantability and fitness for particular purpose, and of all other obligations or liabilities on the Seller's part, and it neither assumes, nor authorizes any other person to assume for the Seller any other liabilities in connection with the sale of products under this order.

WARNING!

This equipment generates, uses and can radiate radio frequency energy. If not installed and used in accordance with the instruction manual - its use may result in interference with radio communication services. As temporarily permitted by regulations, it (the same) has not been tested for compliance (with the limits for class A computing devices) pursuant to sub part J of part 15 of F.C.C. rules, which are designed to provide reasonable protection against such interference. Operation of this equipment in a residential area is may cause interference - in which case, the user, at his own expense, will be required to take whatever measures may be required to correct the interference.

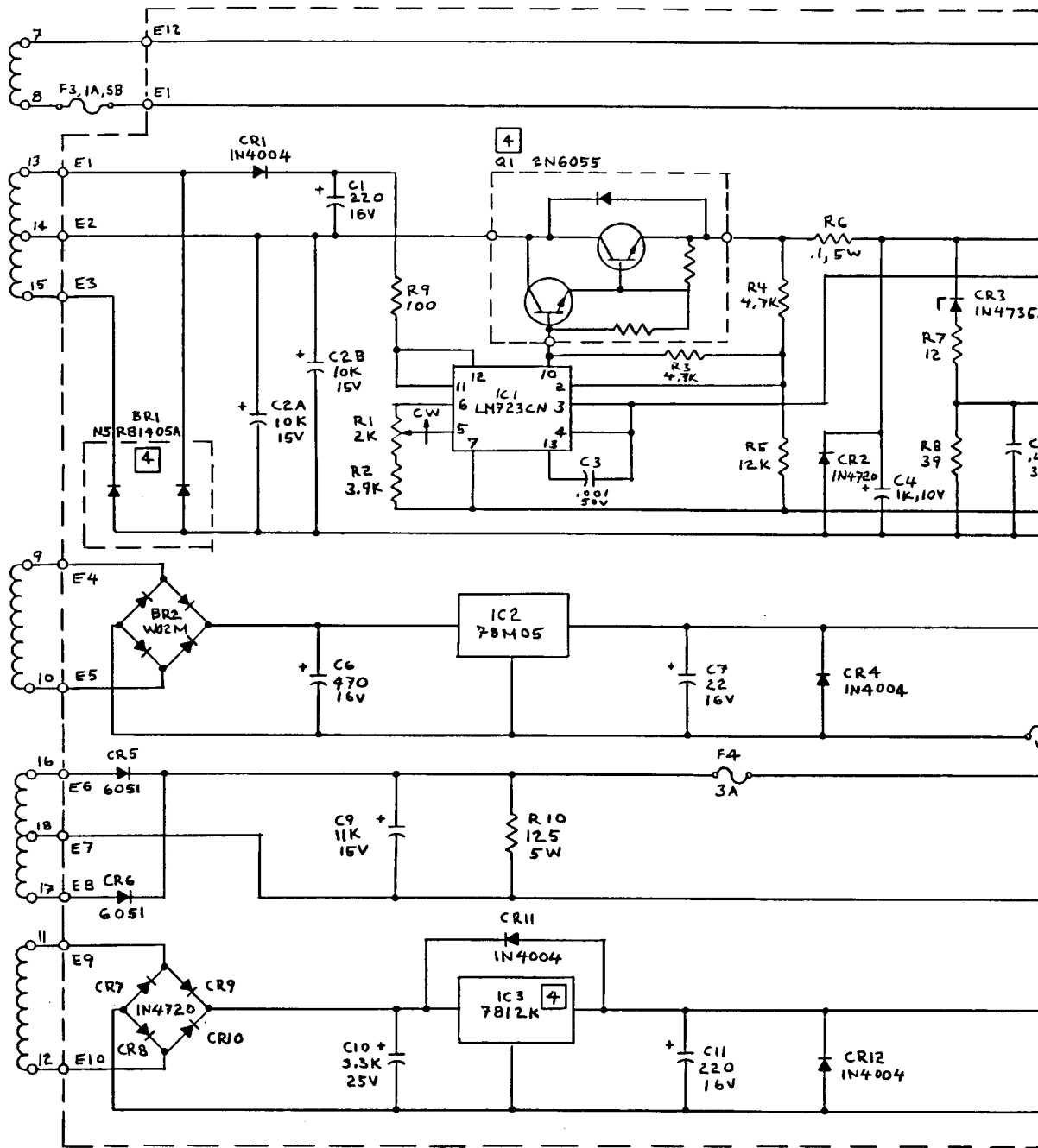

ENT MOUNTED ON CHASSIS.

RESISTANCE VALUES IN OHMS $\pm 5\%$, $\frac{1}{2}$ W.
CAPACITANCE VALUES IN MICROFARADS.

UNLESS OTHERWISE SPECIFIED

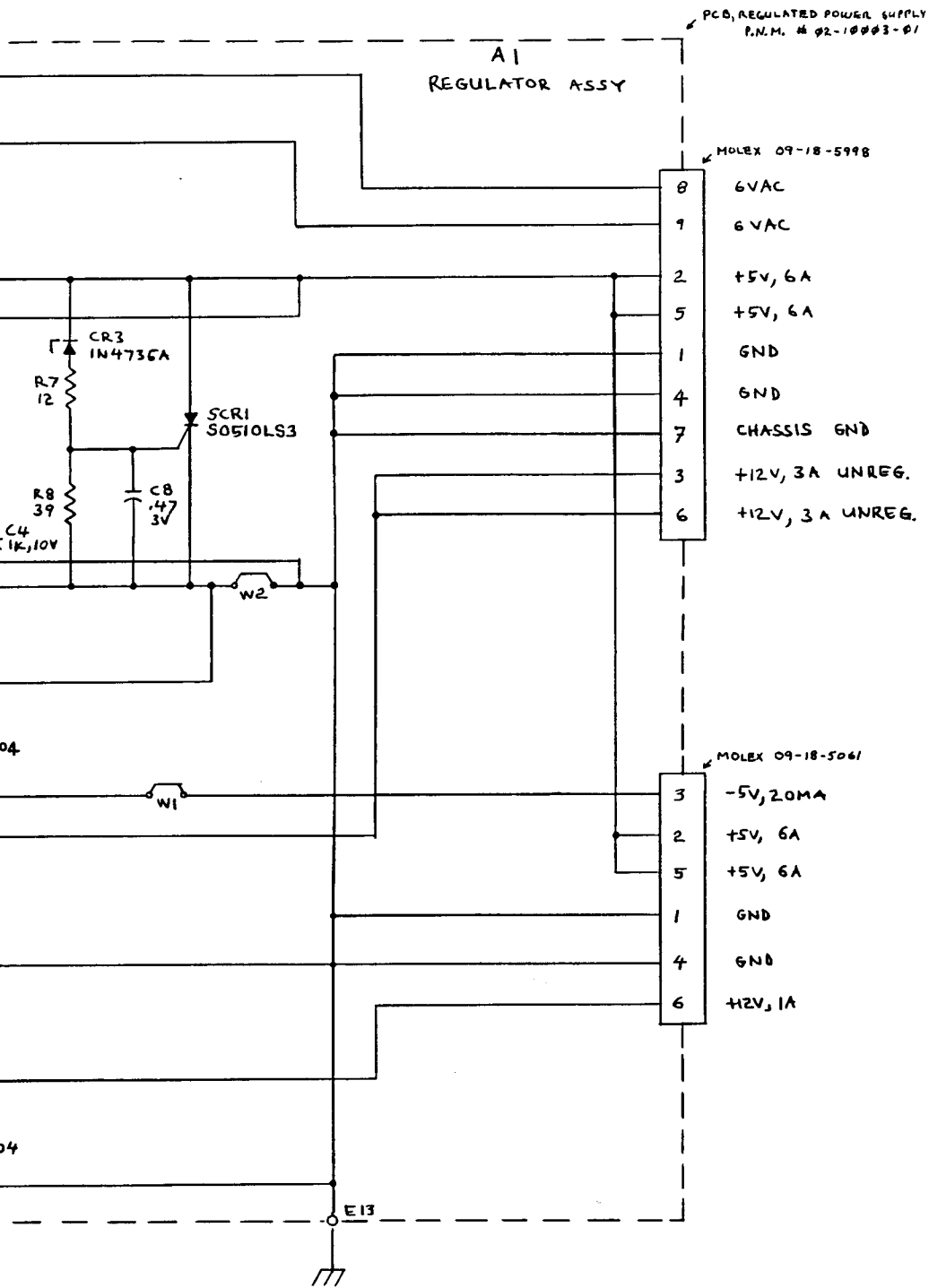

REV.	DRAWN BY	DATE	PACIFIC NOVELTY MANUFACTURING
A	A. J.	10-2-81	MARINA DEL REY CA 90291
B	RSM	5-12-82	ASSY, PCB, REGULATED POWER SUPPLY
			REV. D P.N.M. # 05-10014-01
			SHEET 1 OF 1

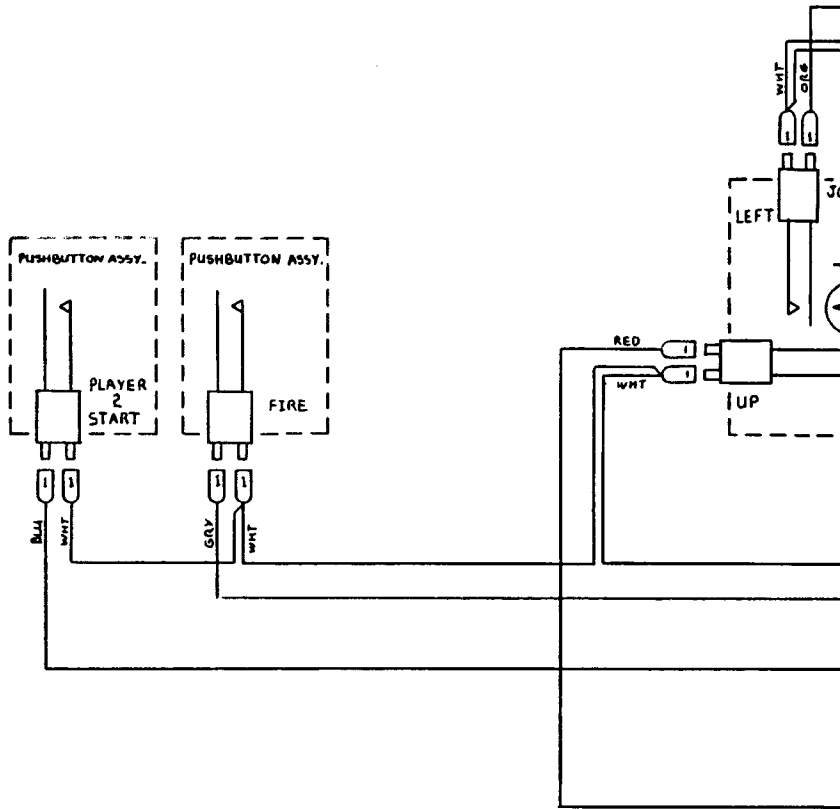

- ① USE .187 x .020 FASTON RECEPT. (20-24 AWG), FULLY INSULATED [QTY. PER ASSY. = 16]
- ② USE MOLEX Ø3-Ø9-2151 PLUG [QTY. PER ASSY. = 1]
- ③ USE MOLEX MALE Ø93 DIAM TERM. Ø2-Ø9-2136 [QTY. PER ASSY. = 7]
- ④ ALL WIRE USE 22 AWG, STRANDING 19x34, PVC INSULATION, 300V, 105°C COLOR AS INDICATED

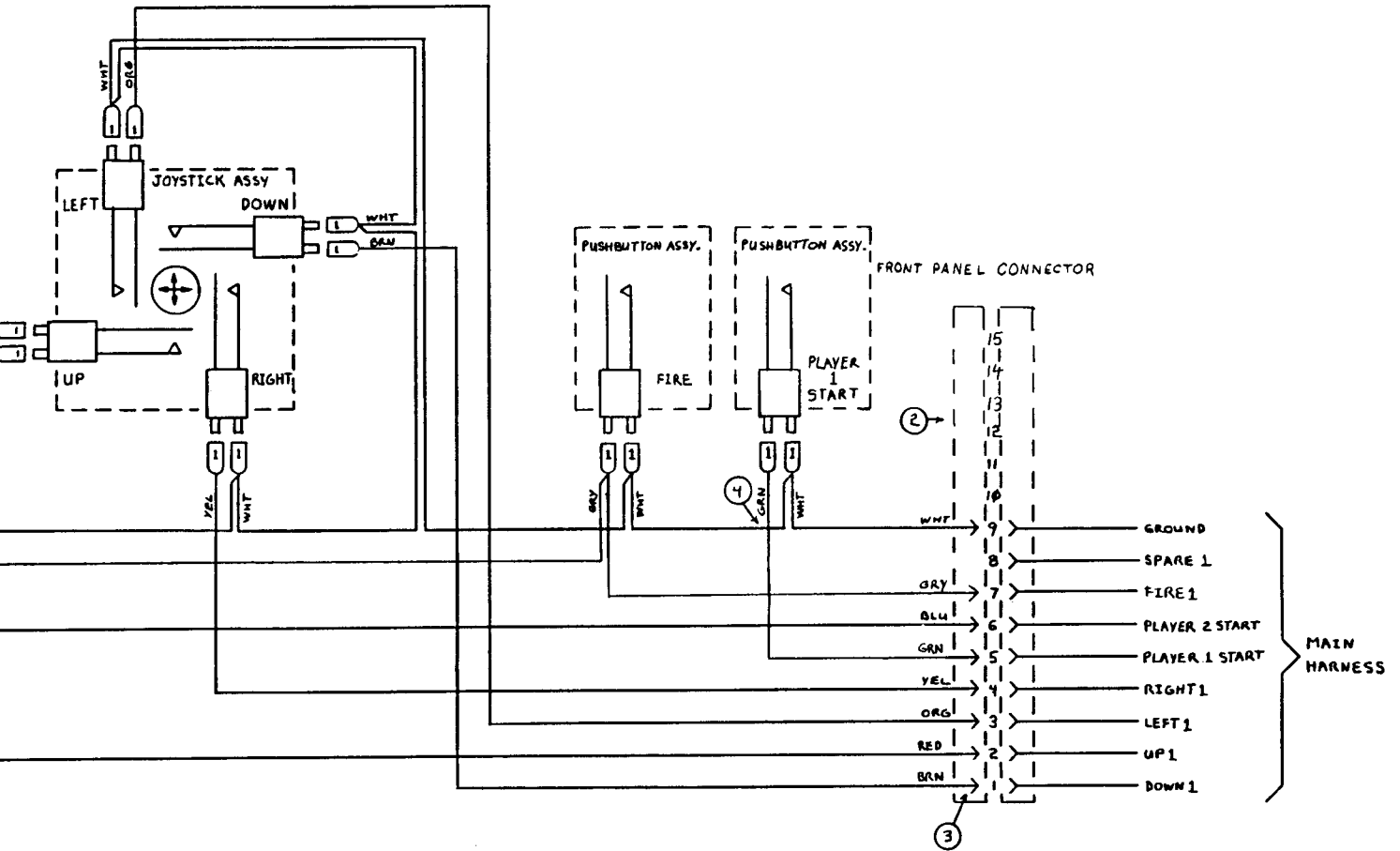

REV.	DRAWN	BY	PACIFIC NOVELTY MANUFACTURING, INC. MARINA DEL REY, CA. ©1981
A	11/8/81	②	Assy., Harness, Control Panel, Nato 05-10031-01
B	2/17/82	④P	
C	5/17/82	④	
D	6/22/82	④	

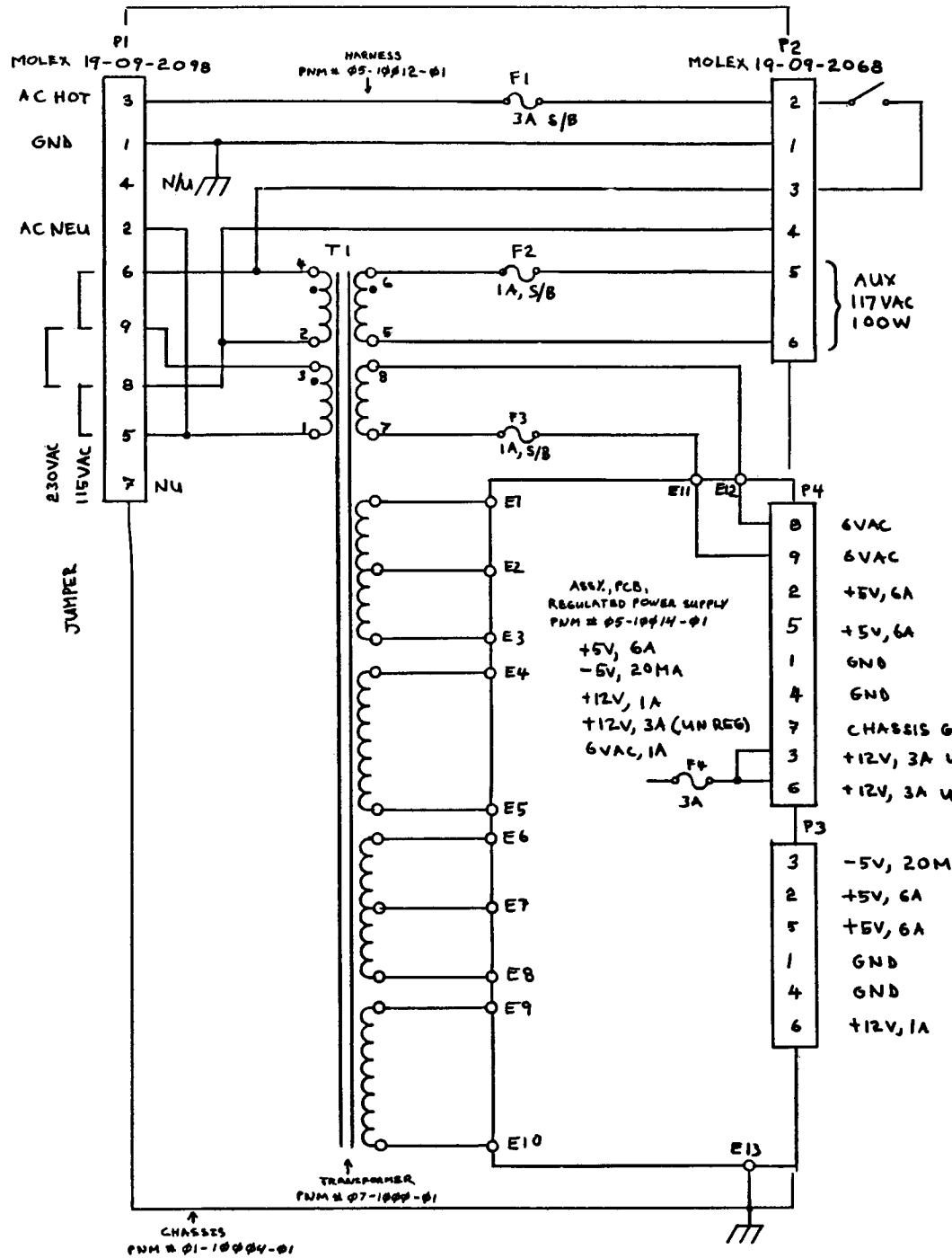

NOTES: UNLESS OTHERWISE SPECIFIED

2
09-2068

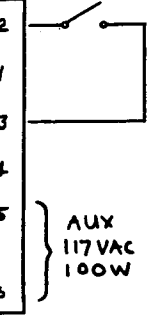

AUX
117VAC
100W

P4

- 3 6VAC
- 7 6VAC
- 2 +5V, 6A
- 5 +5V, 6A
- 1 GND
- 4 GND
- 7 CHASSIS GND
- 3 +12V, 3A UNREG
- 5 +12V, 3A UNREG

P3

- 3 -5V, 20MA
- 2 +5V, 6A
- 7 +5V, 6A
- 1 GND
- 4 GND
- 6 +12V, 1A

REV.	DRAWN BY	DATE	PACIFIC NOVELTY MANUFACTURING	
A	A.S.	10-2-81	MARINA DEL REY CA. 90291	
B	R.S.M.	5-12-82	TITLE	
			ASSY. REGULATED POWER SUPPLY	
			SIZE	PNM # 05-10016-01
			D	
			SHEET 1 OF 1	

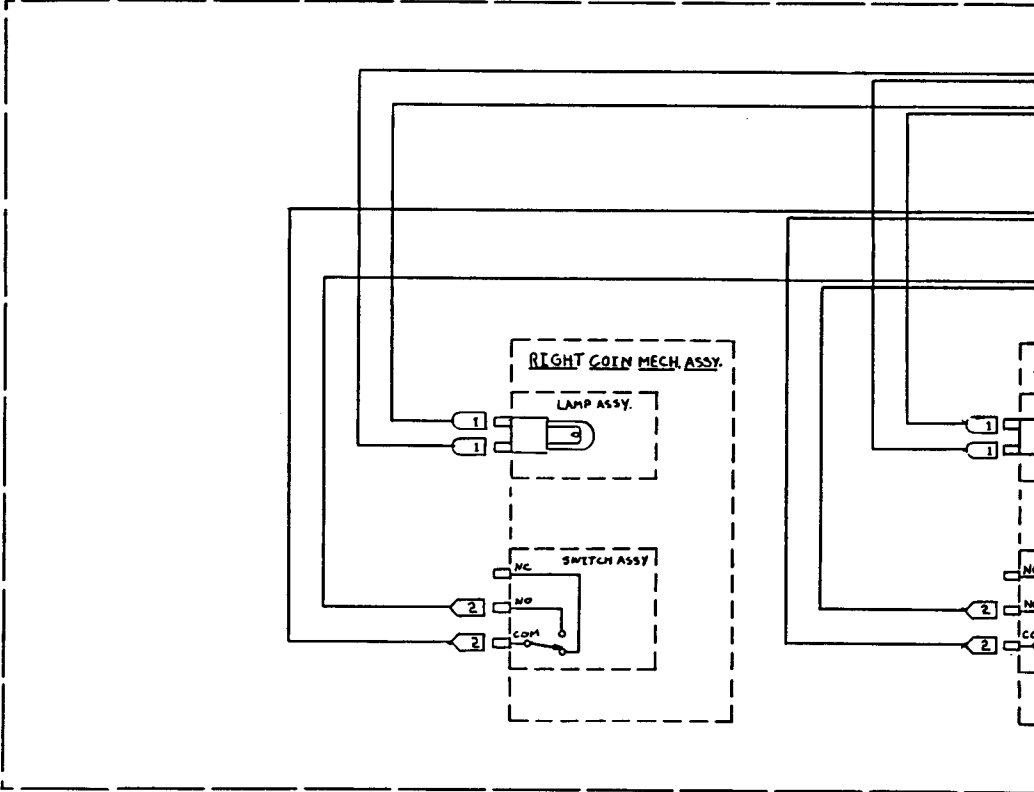

- ① USE .118 x .015 FASTON RECEPT. (20-24 AWG), FULLY INSULATED [QTY. PER ASSY. = 4]
- ② USE .250 x .032 FASTON RECEPT. (20-24 AWG), FULLY INSULATED [QTY. PER ASSY. = 4]
- ③ USE MOLEX 03-09-2092 PLUG [QTY. PER ASSY. = 1]
- ④ USE MOLEX 02-09-2136 MALE .093 DIAM. TERM. [QTY. PER ASSY. = 7]
- ⑤ WIRES JOINED WITH WIRE-NUT
- ⑥ SEMI-STRIP 1/2"
- ⑦ USE #6 STUD SIZE RING TERMINAL
- ⑧ ALL WIRE; USE 22 AWG (19 x 34 STRANDING), PVC INSULATION COLORS AS INDICATED

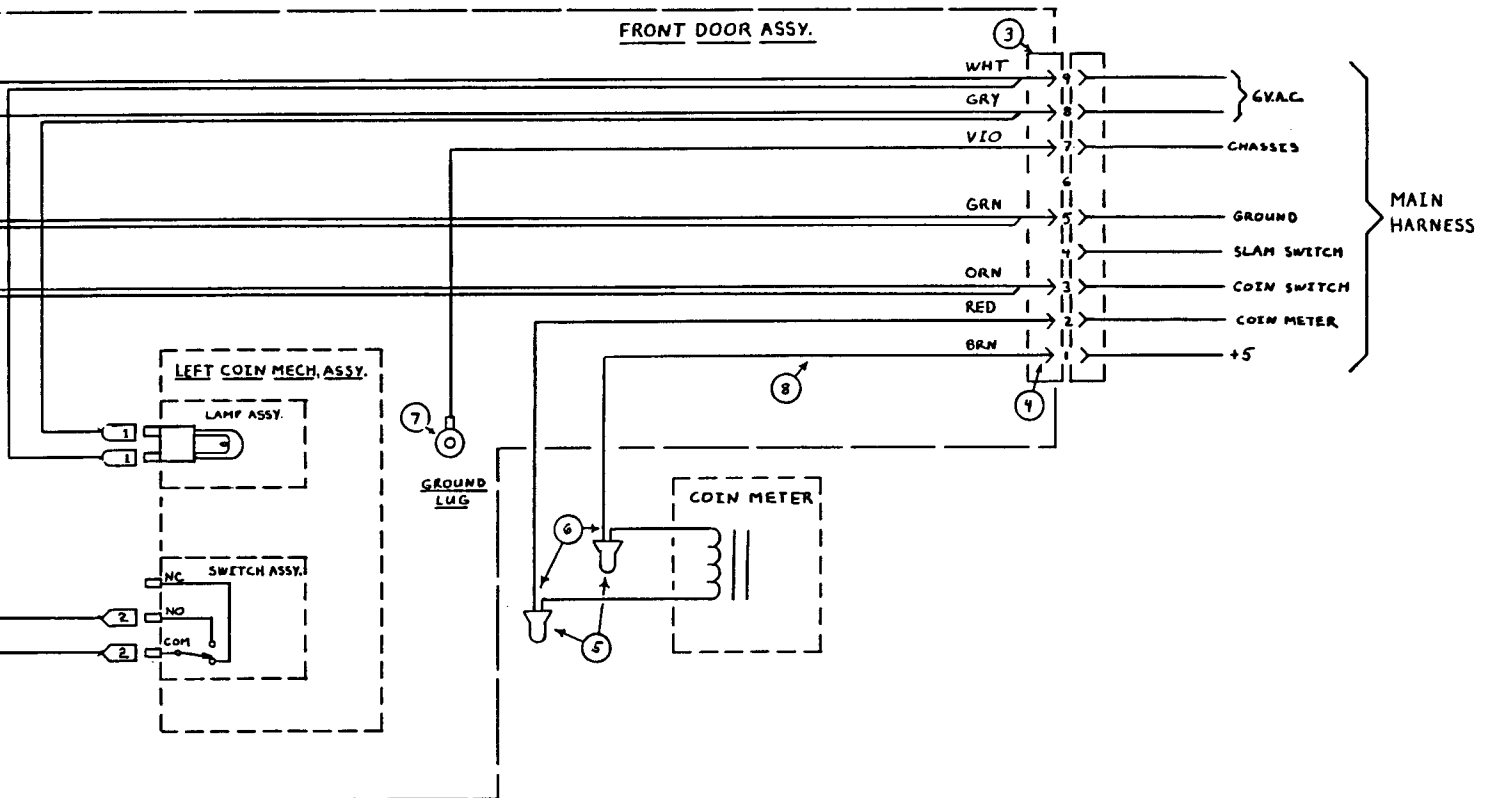

REV.	DRAWN	BY	PACIFIC NOVELTY MANUFACTURING, INC. MARINA DEL REY, CA. ©1982
A	11/8/81	Ⓢ	
B	2/17/82	J.P.	ASSY, HARNESS, COIN DOOR (FOR COIN CONTROL "OVER-UNDER" DOOR)
C	3/22/82	Ⓢ	
D	5/17/82	Ⓢ	05-1005-01

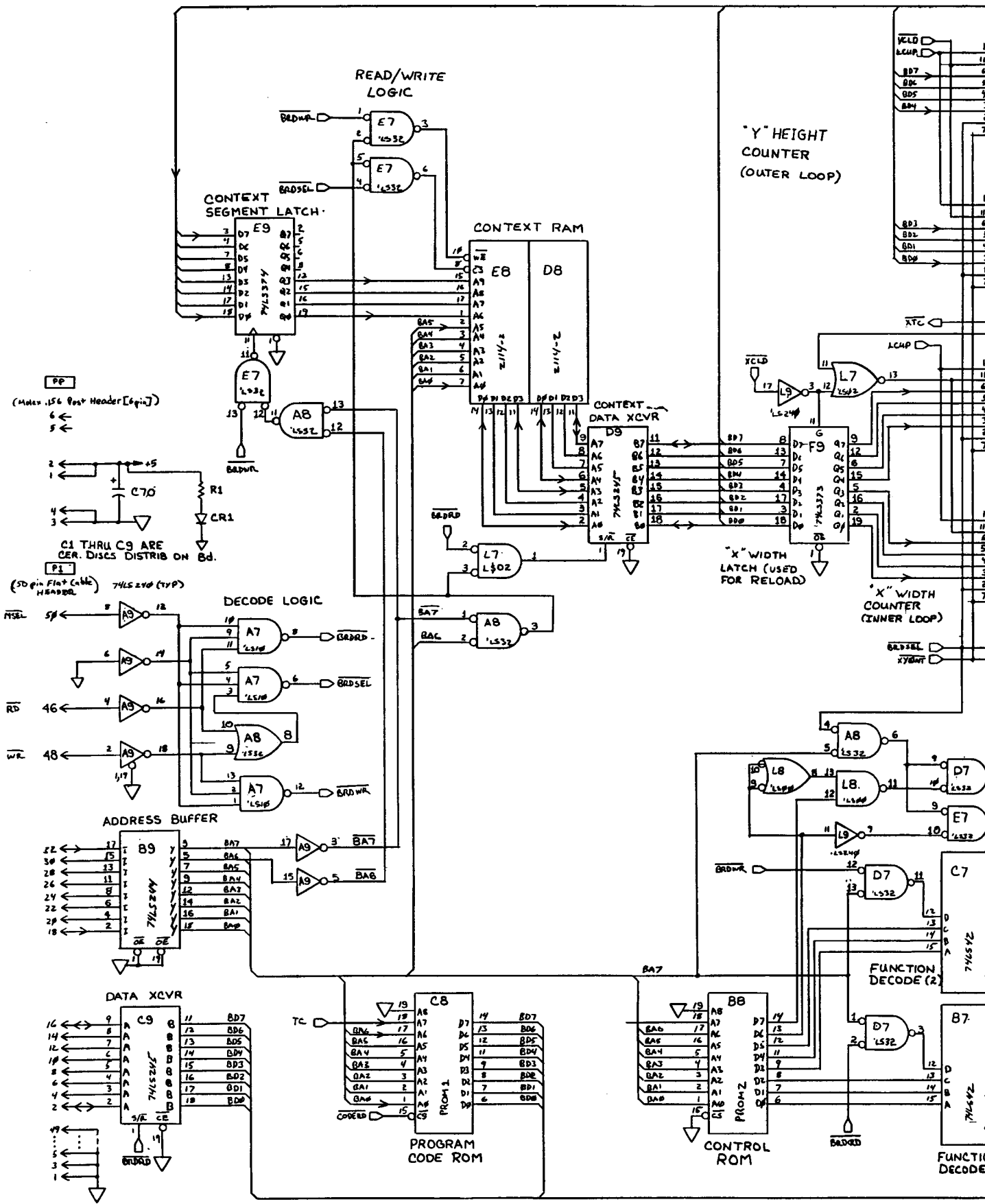

PP
(Max. 156 Pin Header [6pin])
6 ←
5 ←
2 ←
1 ←
4 ←
3 ←

C1 THRU C9 ARE CER. DISCS DISTRIB ON Bd.
P1
(50 pin Flat Cable Header) 74LS240 (10P)

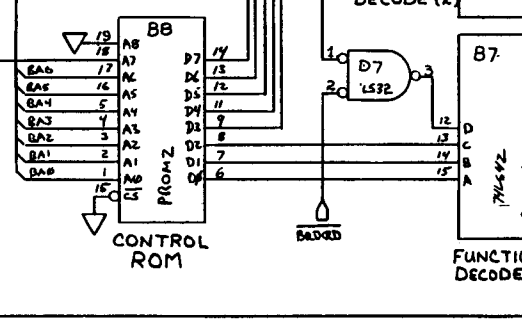
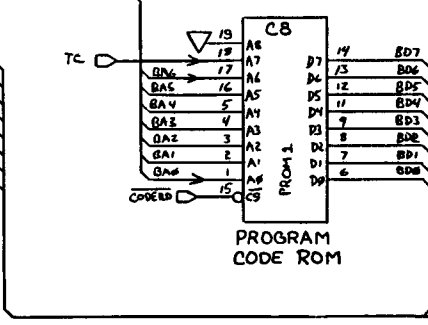
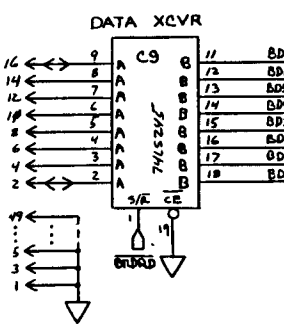
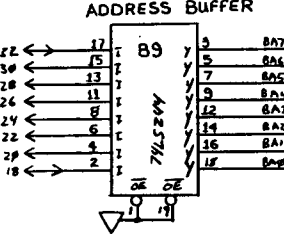
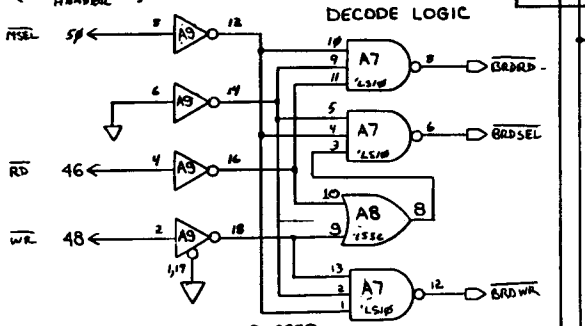

"Y" HEIGHT COUNTER (OUTER LOOP)

"X" WIDTH LATCH (USED FOR RELOAD)

"X" WIDTH COUNTER (INNER LOOP)

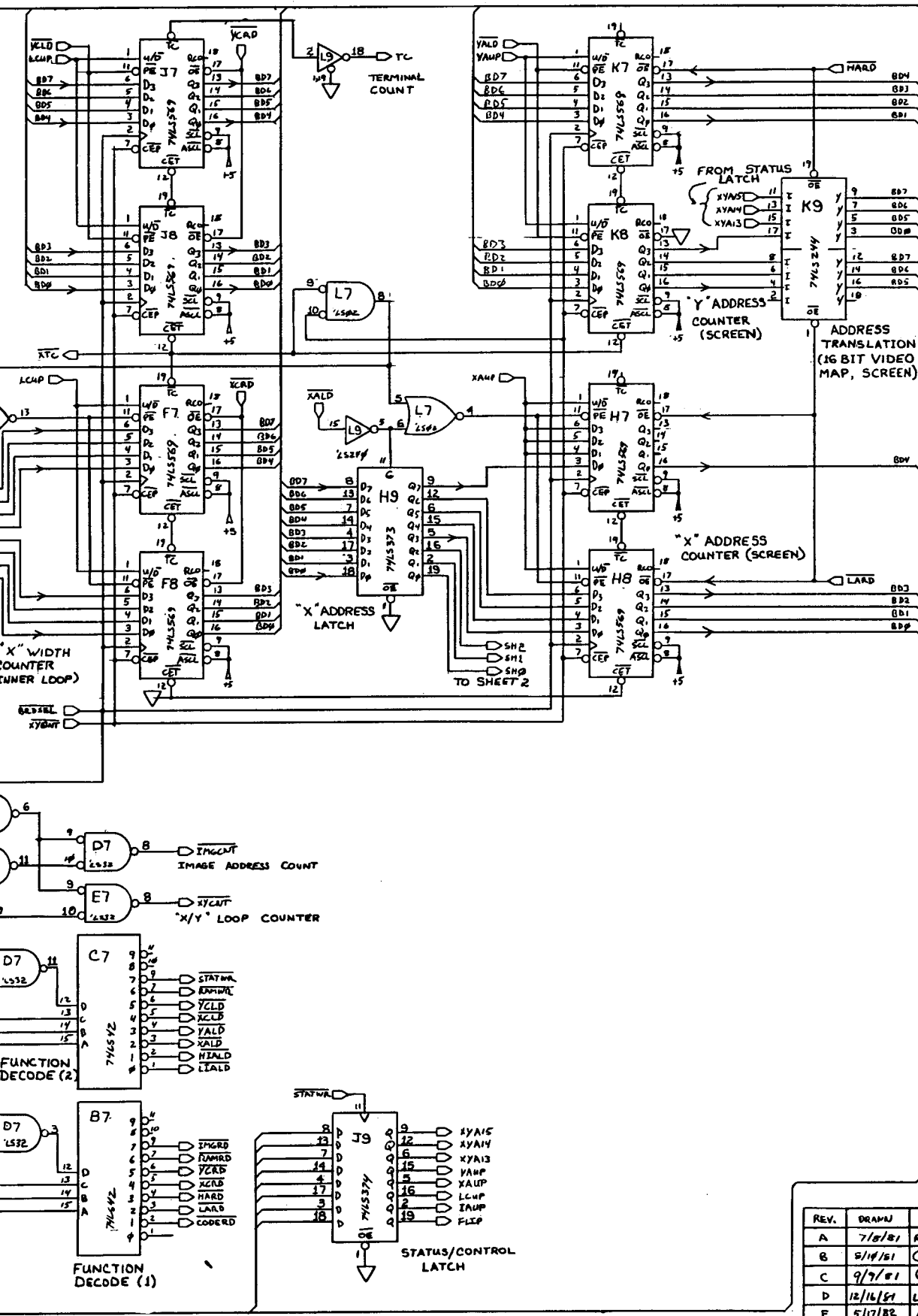

MNEUMONICS TABLE	
BA0-7	BUFFERED ADDRESS 0 THRU 7
BD0-7	BUFFERED DATA 0 THRU 7
BRDRD	BOARD READ
BRSEL	BOARD SELECT
BRDWR	BOARD WRITE
BAG	BUFFERED ADDRESS 6 NOT
BAT	BUFFERED ADDRESS 7 NOT
CODERD	CODE READ
FLIP	FLIP BOTH ENDS OF BARREL
HARD	HIGH ADDRESS READ
HIALD	HIGH ADDRESS LOAD
IAUP	IMAGE ADDRESS COUNT UP
IMGRD	IMAGE READ
LARD	LOW ADDRESS READ
LCUP	LOW ADDRESS COUNT UP
LYALD	LOW ADDRESS LOAD
RAMRD	RAM READ
RAMWR	RAM WRITE
STATWR	STATUS WRITE
XAUP	'X' ADDRESS COUNT UP
XCLD	'X' COUNTER LOAD
XCRD	'X' COUNTER READ
XALD	'X' ADDRESS LOAD
XYA13	'X/Y' ADDRESS 13
XYA14	'X/Y' ADDRESS 14
XYA15	'X/Y' ADDRESS 15
YALD	'Y' ADDRESS LOAD
YAUP	'Y' ADDRESS COUNT UP
YCLD	'Y' COUNTER LOAD
YCRD	'Y' COUNTER READ

BD0-7
TO SHEET 2

REV.	DRAWN	BY	PACIFIC NOVELTY MANUFACTURING MARINA DEL REY, CA 90291 (1981)
A	7/10/81	R. M. [Signature]	
B	8/19/81	[Signature]	ASSY., P.C.B., NATO
C	9/7/81	[Signature]	CO-PROCESSOR REV 0
D	12/16/81	L. CAMMELL	05-10033-01
E	5/17/82	[Signature]	
F	5/24/82	[Signature]	SHEET 1 OF 2

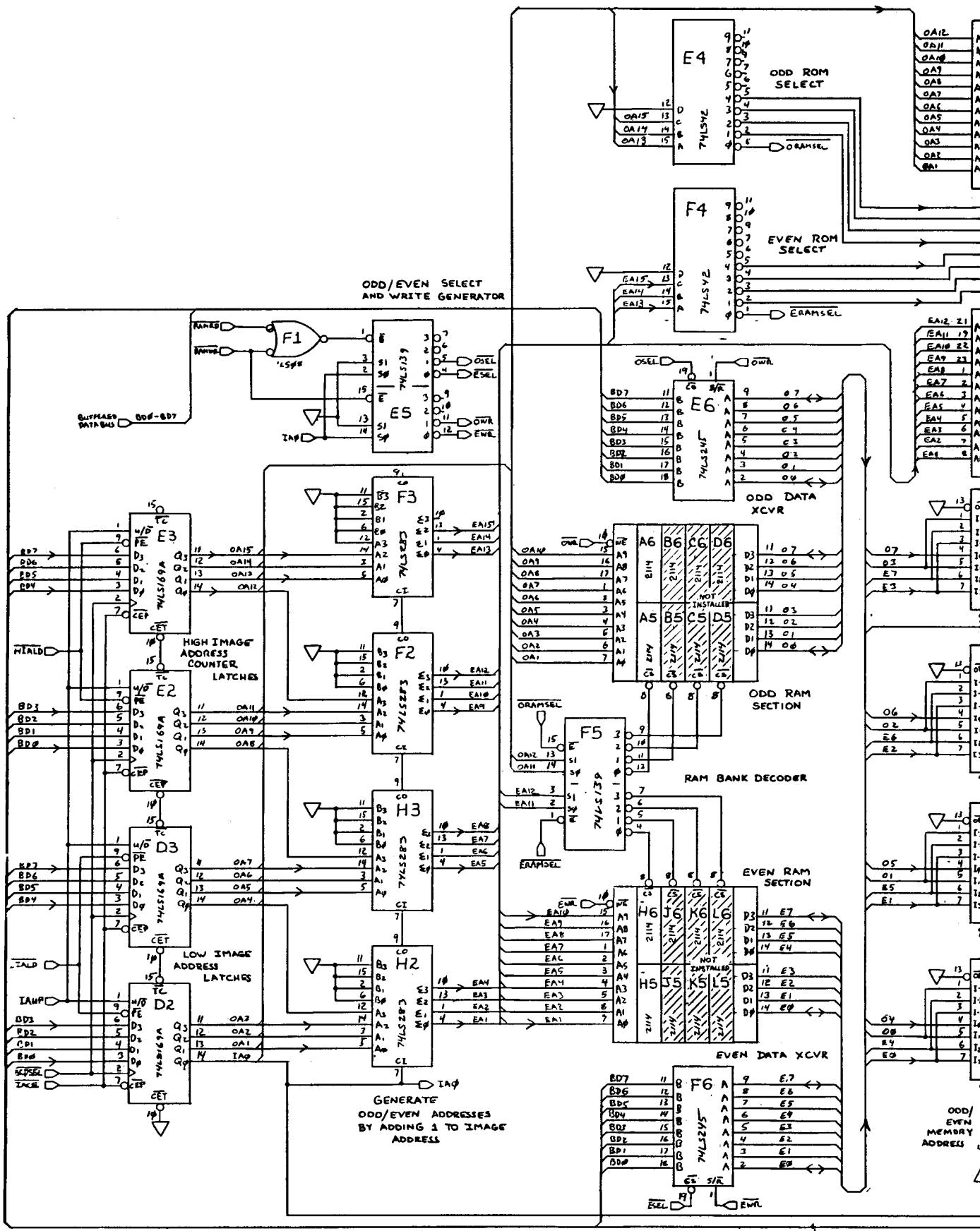

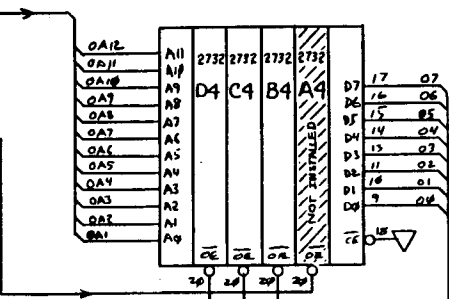

ODD-ADDRESS
IMAGE ROM

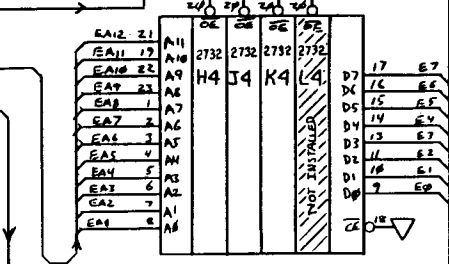

EVEN ADDRESS
IMAGE ROM

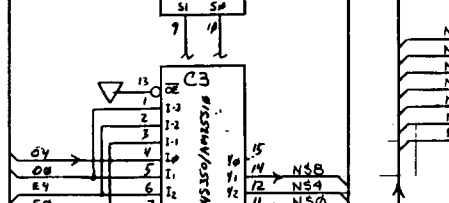
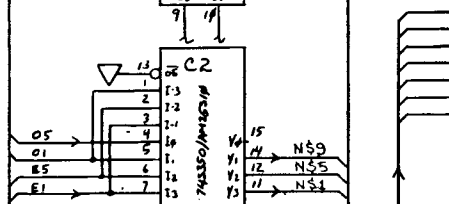
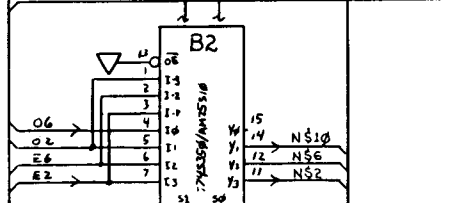
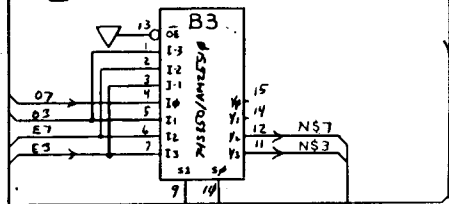

"N" SHIFT DATA
INTERMEDIATE SIGNAL

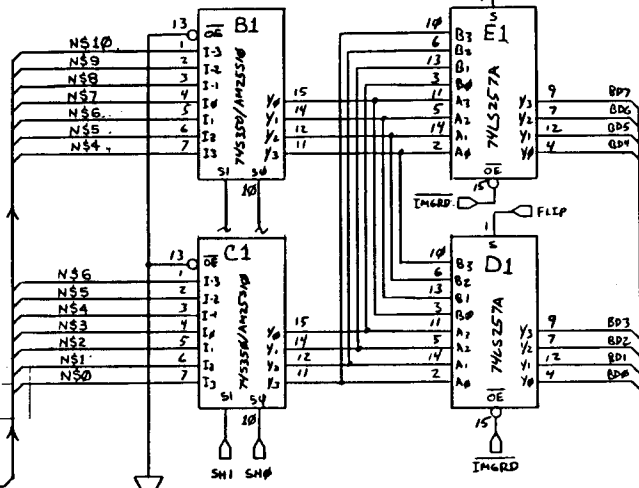

HIGH ORDER
BARREL SHIFT
UPPER/LOWER 4

LOW ORDER
BARREL SHIFT
1:4

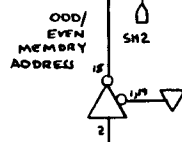

REV	DRAWN	BY	PACIFIC NOVELTY MANUFACTURING
A	7/8/81	R. [Signature]	Marina Del Rey, CA 90291 ©1981
B	8/14/81	[Signature]	ASSY. PCB., NATO COPROCESSOR
C	9/7/81	[Signature]	REV 0
D	12/16/81	L. [Signature]	05-10033-01
E	5/17/82	[Signature]	
F	7/24/82	[Signature]	SHEET 2 of 2

PB0 TO PB8 ARE 48K TO GND
ONE PULL DOWN SWITCH ONLY

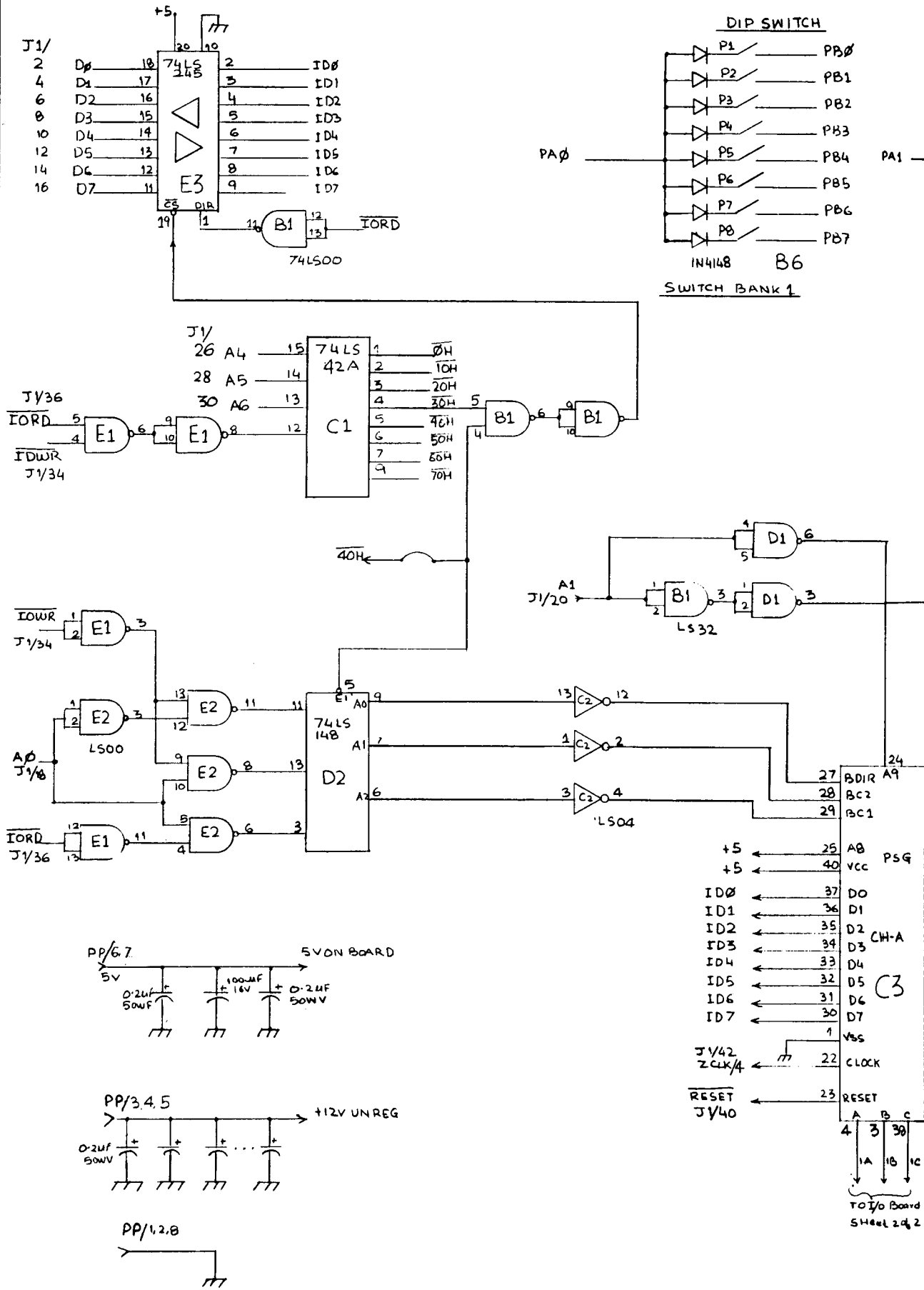

ARE 48K TO GND
SWN SWITCH ONLY

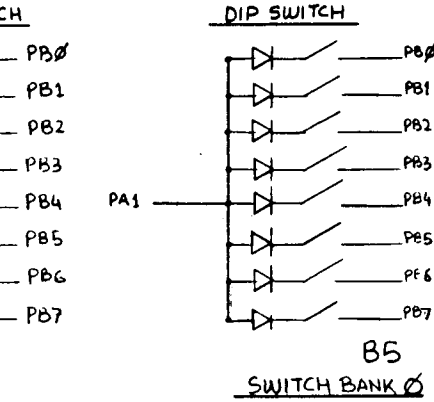

REVISIONS			
LTR	DESCRIPTION	DATE	APPROVED
A	PRODUCTION CHANGES	01 29 81	<i>[Signature]</i>
B	REVISE TITLE, ADD ASSY. NO.	5/17/82	Ⓢ
C	CHANGE SWITCH INPUT LABELING	6/22/82	Ⓢ

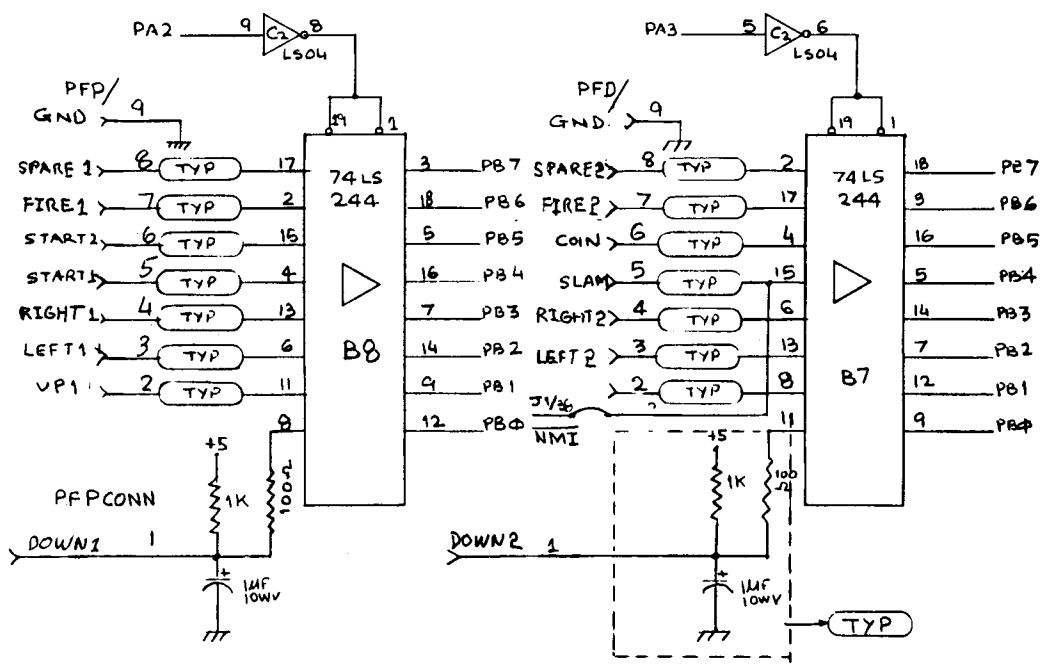
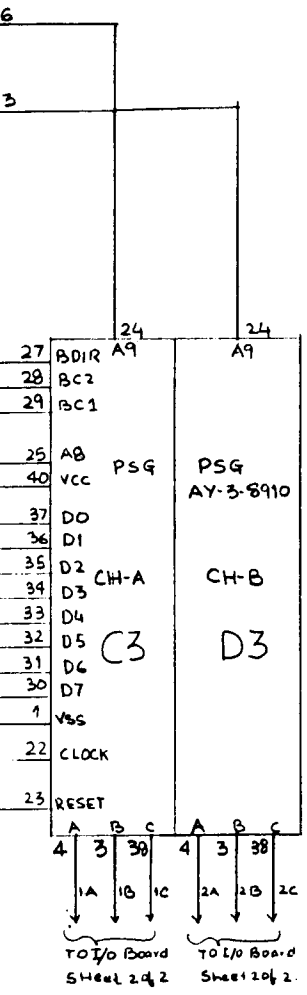
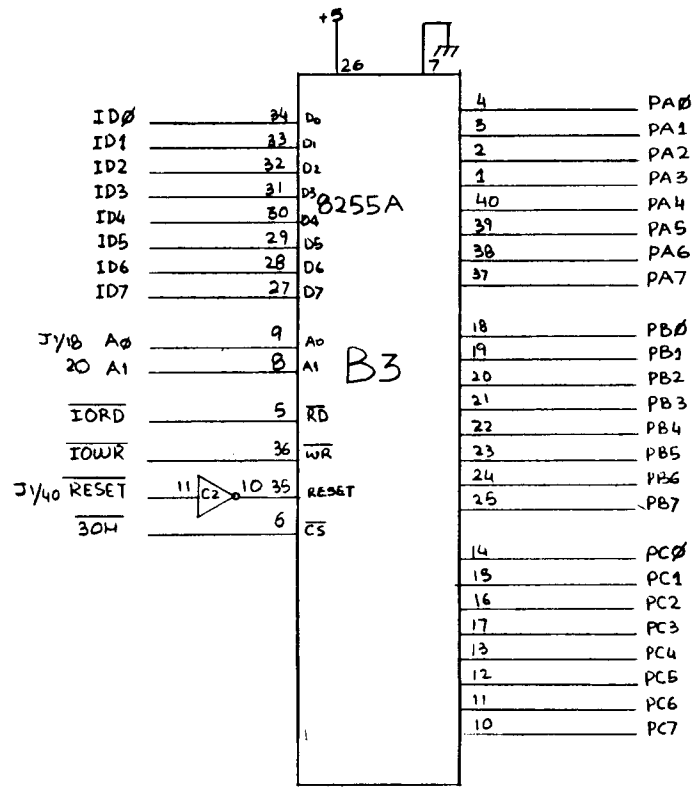

TOLERANCES UNLESS OTHERWISE SPECIFIED FRACTIONS DEC ANGLES ± ± ±		PACIFIC NOVELTY MANUFACTURING MARINA DEL REY, CA-90241	
APPROVALS <i>[Signature]</i>		DATE 12/15/81	
DRAWN C. Campbell		ASSY., P.C.B., I/O BOARD REV 2A 05-10034-01	
CHECKED <i>[Signature]</i>		SCALE	SIZE C
		DRAWING NO.	
		DO NOT SCALE DRAWING	
		SHEET 1 OF 2	

FROM PSC
SHEET 1 OF 2

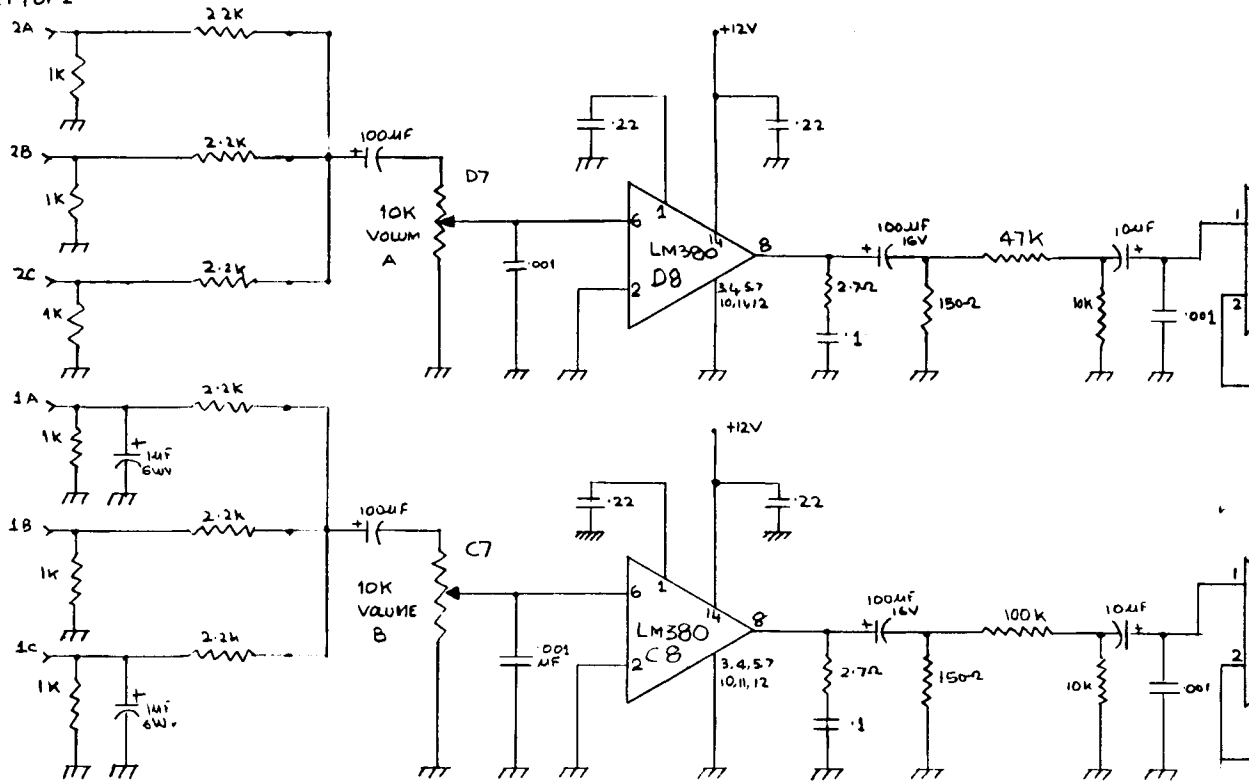

FROM
B 3
(8255)

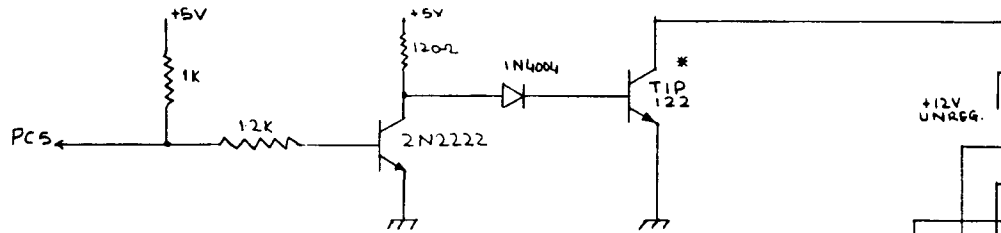

FROM
B-3

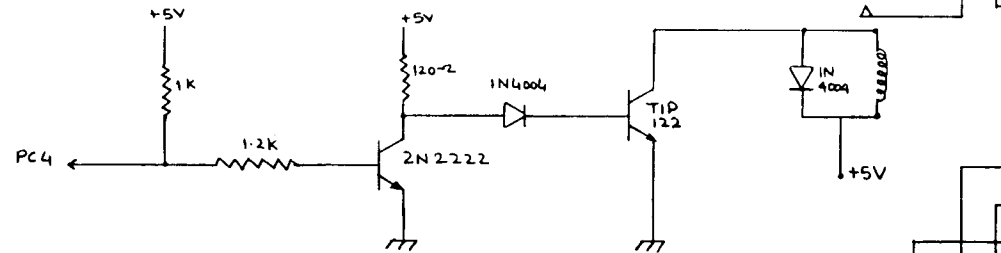

FROM
B-3

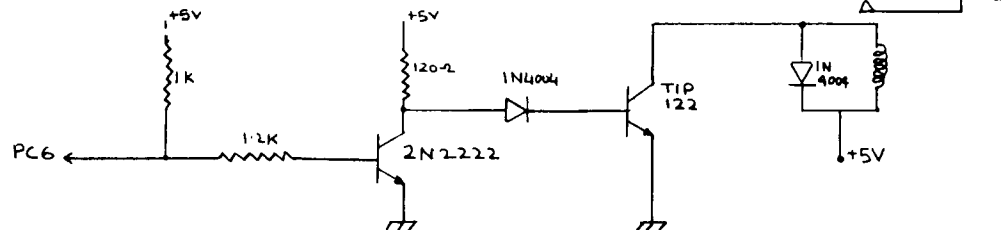

REVISIONS			
LTR	DESCRIPTION	DATE	APPROVED
A	PRODUCTION CHANGES	01/30/81	02/02/81 [Signature]
B	CHANGE TITLE, ADD ASSY. NO.	5/17/82	[Signature]
C	CHANGE SWITCH INPUT LABELING	6/22/82	[Signature]

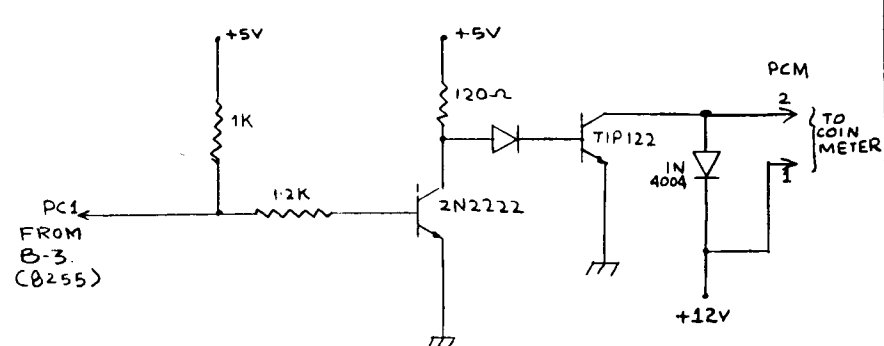
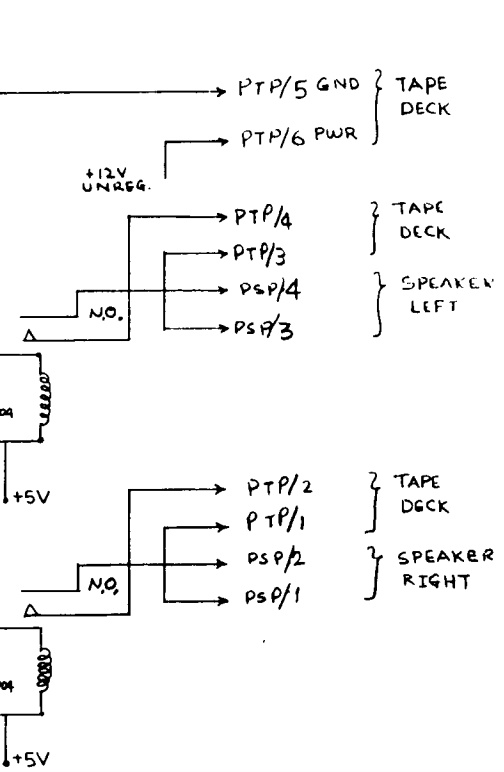
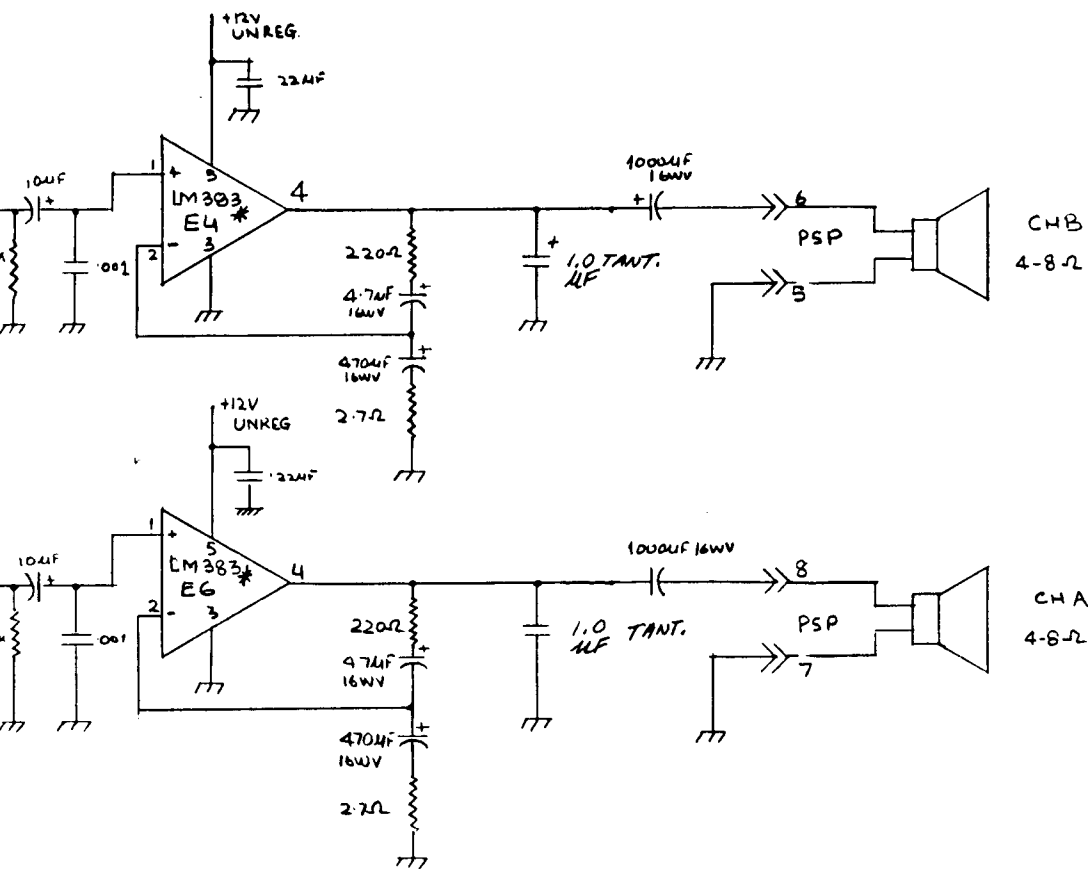

* HEAT SINK

TOLERANCES UNLESS OTHERWISE SPECIFIED		PACIFIC NOVELTY MANUFACTURING	
FRACTIONS DEC ANGLES		MARINA DEY REV, CA-90291	
±	±	ASSY, PCB, I/O BOARD REV 2A	
APPROVALS		05-10034-01	
DATE		SCALE	SIZE
DRAWN		DRAWING NO.	
CHECKED		C	
DATE		DO NOT SCALE DRAWING	
DATE		SHEET 2 OF 2	

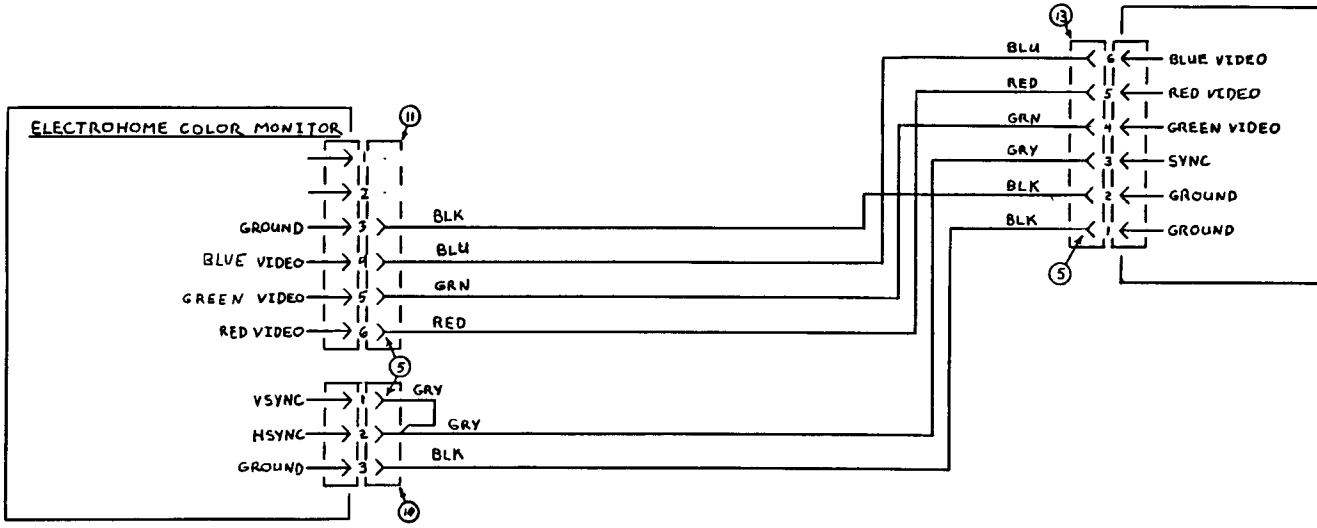
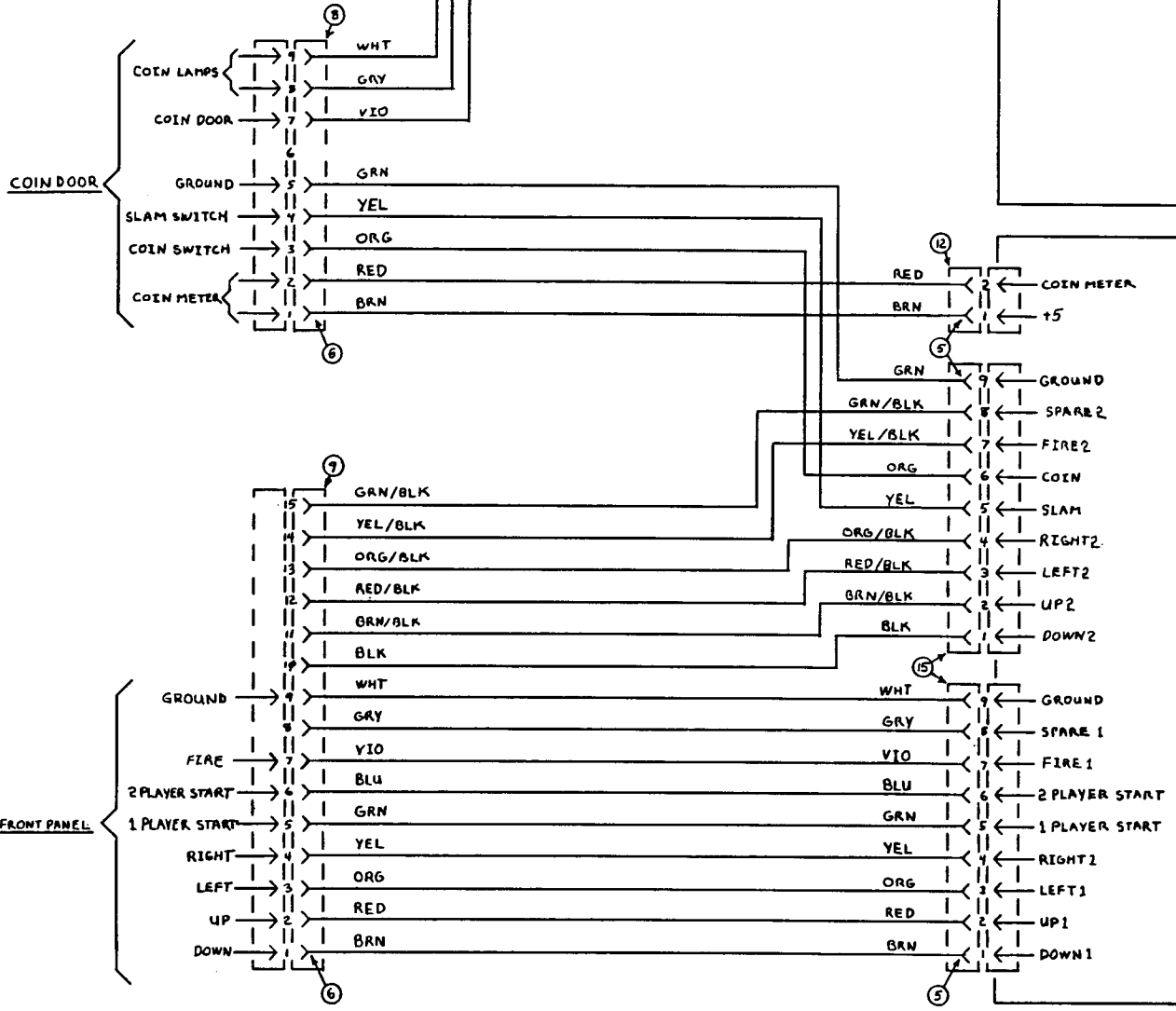

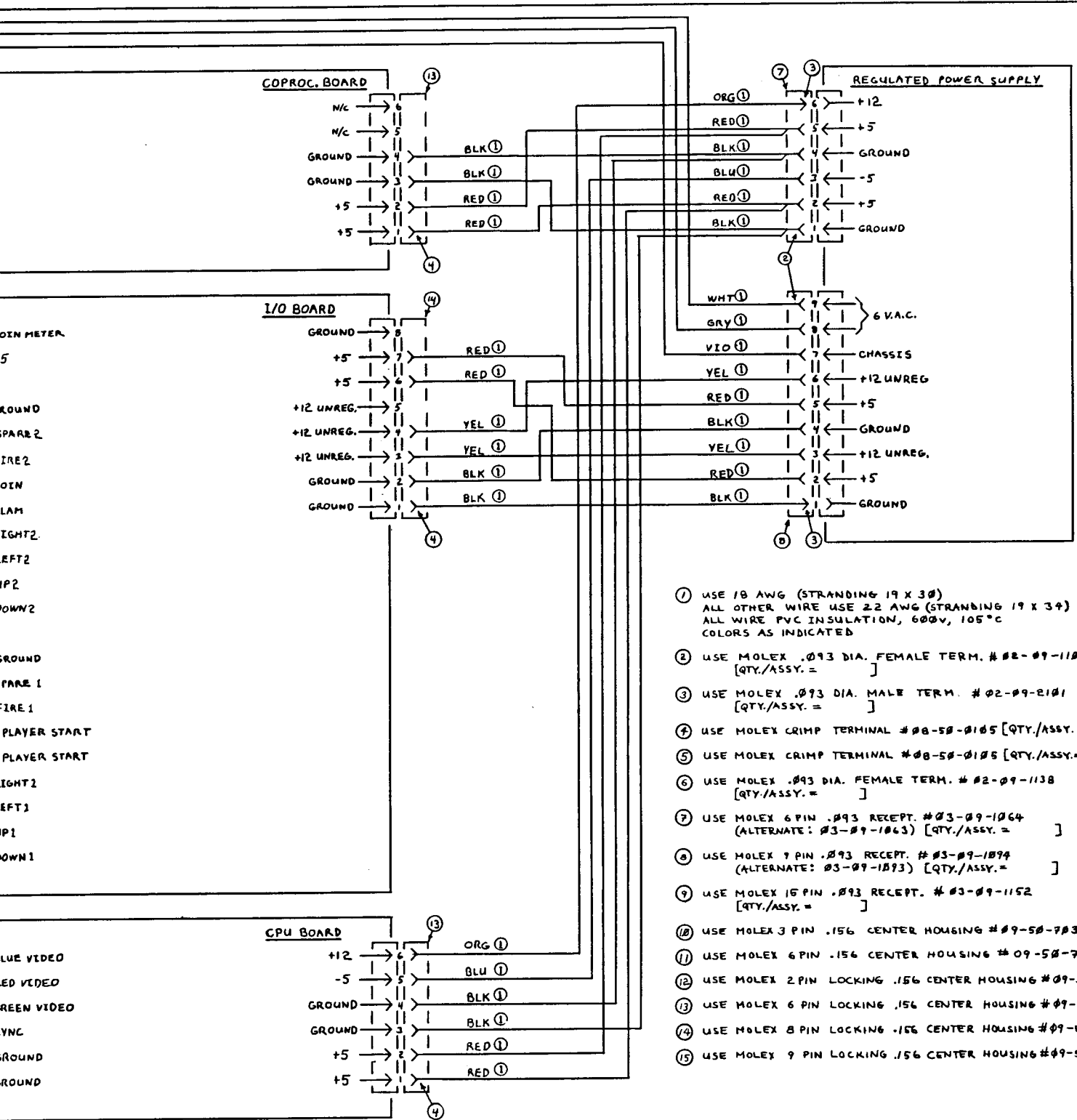

- ① USE 18 AWG (STRANDING 19 X 30)
ALL OTHER WIRE USE 22 AWG (STRANDING 19 X 34)
ALL WIRE PVC INSULATION, 600V, 105°C
COLORS AS INDICATED
- ② USE MOLEX .093 DIA. FEMALE TERM. # 02-09-1102 [QTY./ASSY. =]
- ③ USE MOLEX .093 DIA. MALE TERM. # 02-09-2101 [QTY./ASSY. =]
- ④ USE MOLEX CRIMP TERMINAL # 08-50-0105 [QTY./ASSY. =]
- ⑤ USE MOLEX CRIMP TERMINAL # 08-50-0106 [QTY./ASSY. =]
- ⑥ USE MOLEX .093 DIA. FEMALE TERM. # 02-09-1138 [QTY./ASSY. =]
- ⑦ USE MOLEX 6 PIN .093 RECEPT. # 03-09-1064 (ALTERNATE: 03-09-1063) [QTY./ASSY. =]
- ⑧ USE MOLEX 9 PIN .093 RECEPT. # 03-09-1094 (ALTERNATE: 03-09-1093) [QTY./ASSY. =]
- ⑨ USE MOLEX 15 PIN .093 RECEPT. # 03-09-1152 [QTY./ASSY. =]
- ⑩ USE MOLEX 3 PIN .156 CENTER HOUSING # 09-50-7031
- ⑪ USE MOLEX 6 PIN .156 CENTER HOUSING # 09-50-7061
- ⑫ USE MOLEX 2 PIN LOCKING .156 CENTER HOUSING # 09-50-3021
- ⑬ USE MOLEX 6 PIN LOCKING .156 CENTER HOUSING # 09-50-3061
- ⑭ USE MOLEX 8 PIN LOCKING .156 CENTER HOUSING # 09-50-3081
- ⑮ USE MOLEX 9 PIN LOCKING .156 CENTER HOUSING # 09-50-3091

REV	DRAWN	BY	PACIFIC NOVELTY MANUFACTURING, INC. MARINA DEL REY, CALIF	©1981
A	11/8/81	Ⓢ		
B	2/3/82	FP	Assy., Harness, NATO MAIN (FRONT PANEL, FRONT DOOR, DC POWER, VIDEO)	
C	3/4/82	FP	05-10000-01	
D	5/17/82	Ⓢ		
E	6/22/82	Ⓢ		

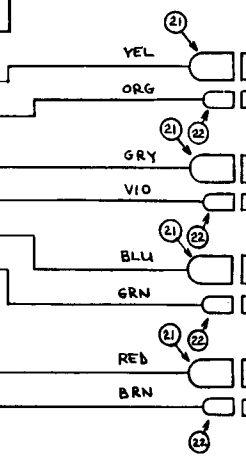
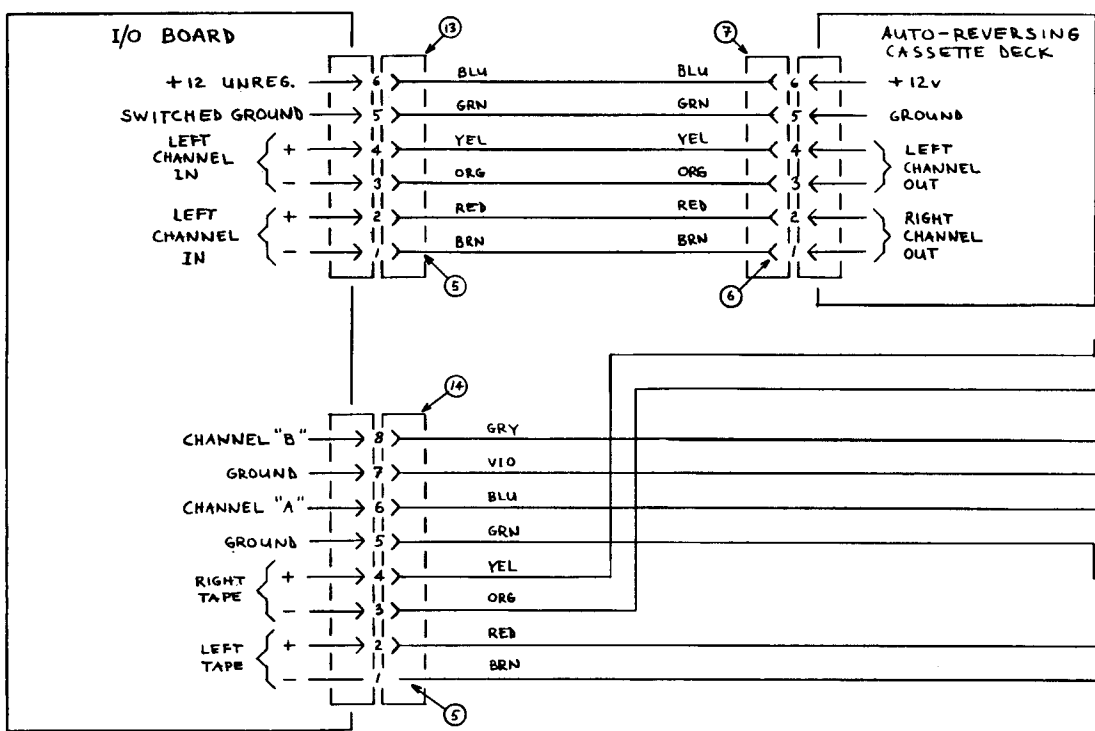
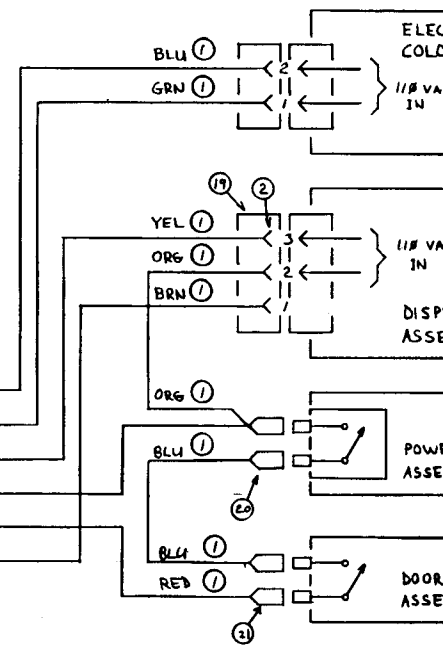
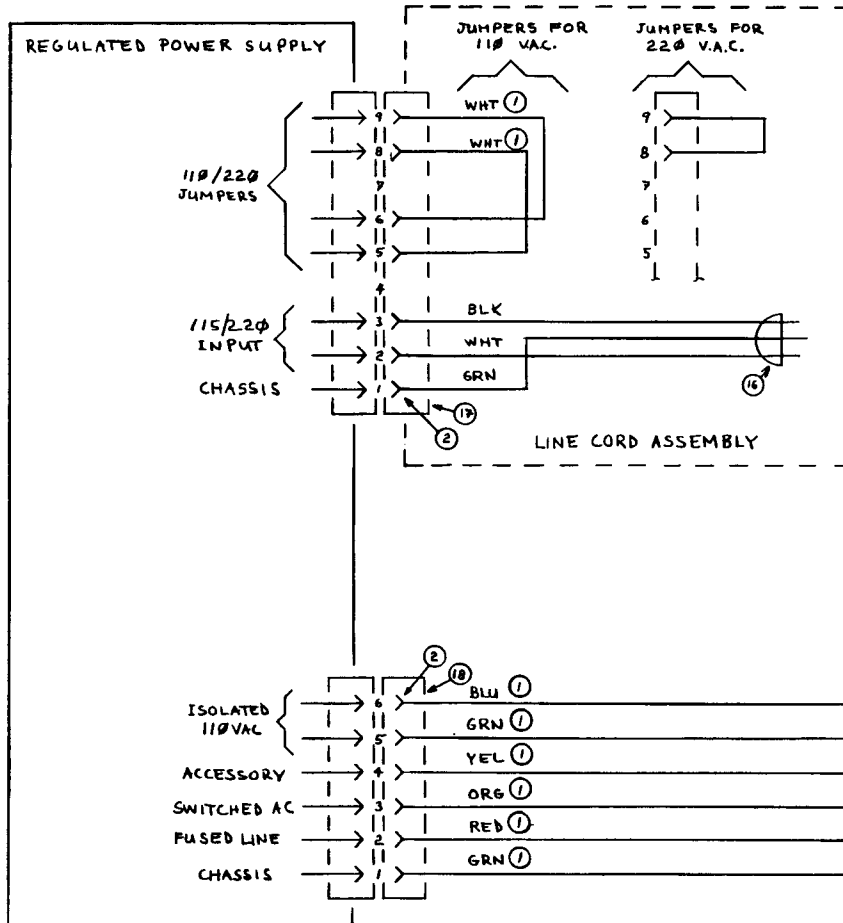

- ⑬ THREE CONDUCTOR POWER SUPPLY CORD, 18 AWG (STRANDING 16 x 3 ϕ), 8' LENGTH, BLACK SJT VINYL JACKET
- ⑭ USE MOLEX 9 PIN .093 INTERNATIONAL RECEPT. # 19-09-1099
- ⑮ USE MOLEX 6 PIN .093 INTERNATIONAL RECEPT. # 19-09-1069
- ⑯ USE MOLEX 3 PIN .093 RECEPT. # 03-09-1032 (ALTERNATE: 03-09-1033)
- ⑰ USE .25 ϕ " BY .032" FASTON RECEPT., FULLY INSULATED
- ⑱ USE .2 ϕ " BY .032" FASTON RECEPT., FULLY INSULATED
- ⑳ USE .11 ϕ " BY .032" FASTON RECEPT., FULLY INSULATED
- ㉑

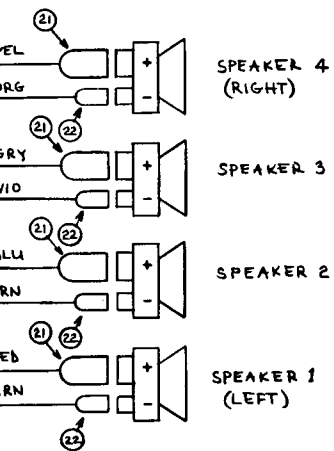
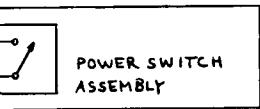
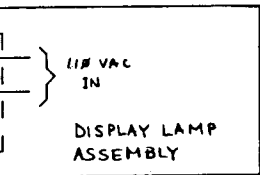
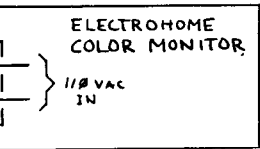

REV.	DRAWN	BY	PACIFIC NOVELTY MANUFACTURING, INC. MARINA DEL REY, CA
A	11-11-81	GD	© 1981
B	2/3/82	JP	05-10000-01
C	3/4/82	JP	Assy., Harness, UPRIGHT MAIN
D	5/17/82	Ⓟ	(AC. POWER, LINE CORD, SPEAKERS, TAPEDECK)
E	6/23/82	Ⓟ	

1. USE JUMPERS J1 &
2. CHIP SELECT ARE P20

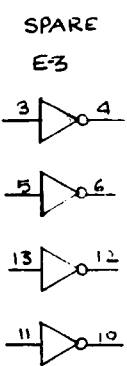
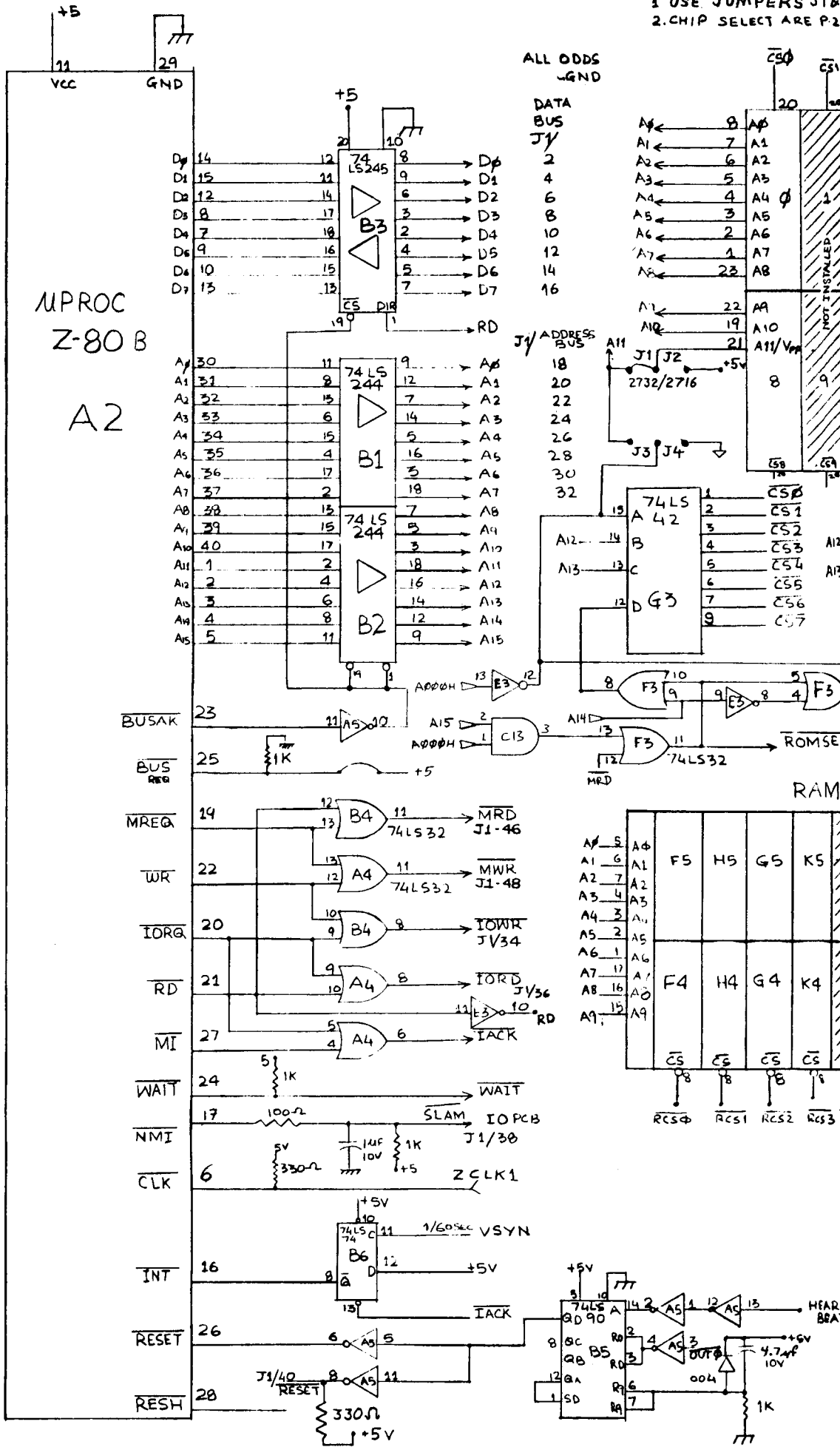

ALL ODDS
-GND

DATA
BUS
JY

2	8	D0
4	9	D1
6	6	D2
8	3	D3
10	2	D4
12	4	D5
14	5	D6
16	7	D7

JY ADDRESS
BUS

18	9	A0
20	12	A1
22	7	A2
24	14	A3
26	5	A4
28	16	A5
30	3	A6
32	18	A7
	19	A8
	5	A9
	3	A10
	18	A11
	16	A12
	14	A13
	12	A14
	9	A15

RAM

A0	5	A4				
A1	6	A1	F5	H5	G5	K5
A2	7	A2				
A3	4	A3				
A4	3	A11				
A5	2	A5				
A6	1	A6				
A7	17	A7				
A8	16	A0	F4	H4	G4	K4
A9	15	A9				

JUMPERS J1 & J4 FOR 2732 ROMS. USE J2 & J3 FOR 2716 ROM
 SELECT ARE P20 AND TITLED CS0 THRU CS15.

		REVISIONS	DATE	APPROVED
LTR		DESCRIPTION		
A		PRODUCTION CHANGES	01 30 82	<i>[Signature]</i>
B		REV 2A ECO # 2, 4, & 6	02 OF 82	
C		CHANGE TITLE, ADDRESS V0, ADD REV 3 ECO#	4/22/82	

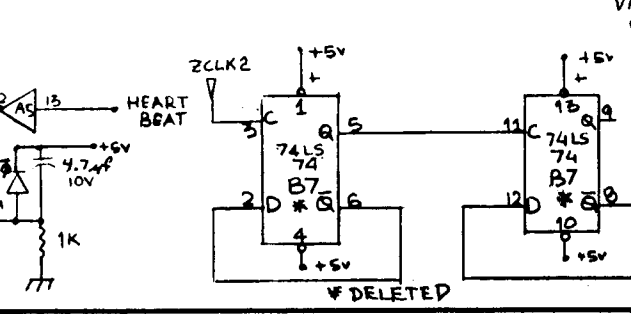
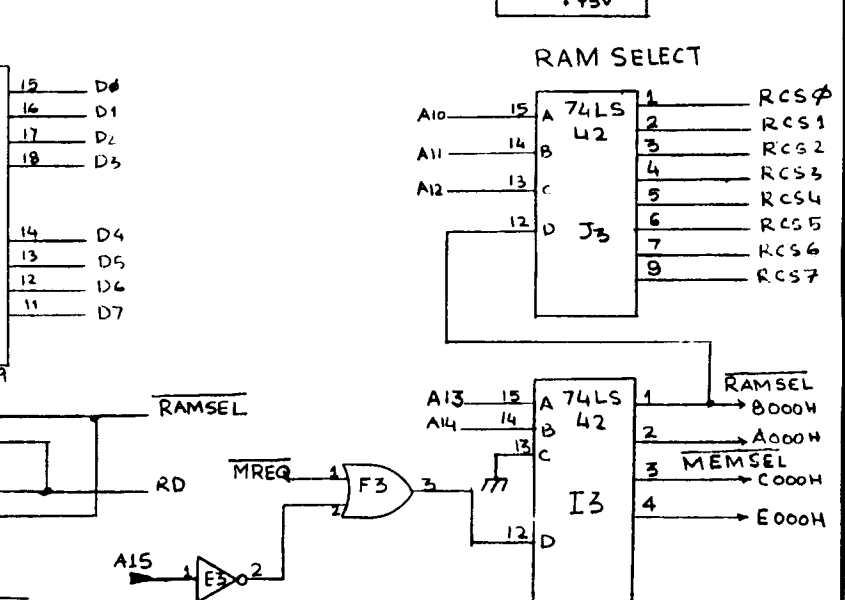
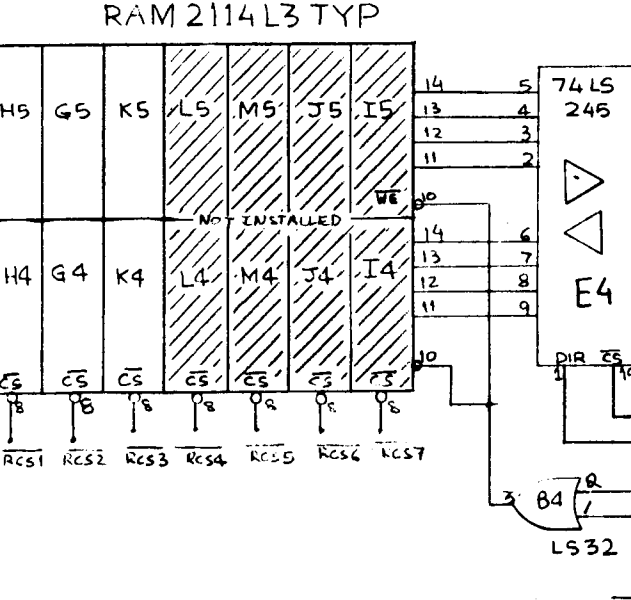
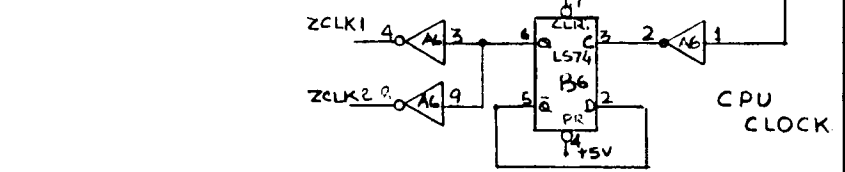
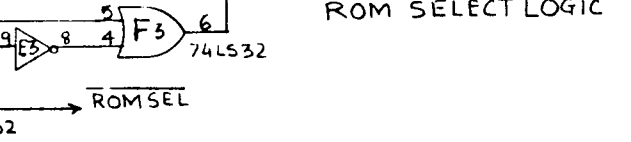
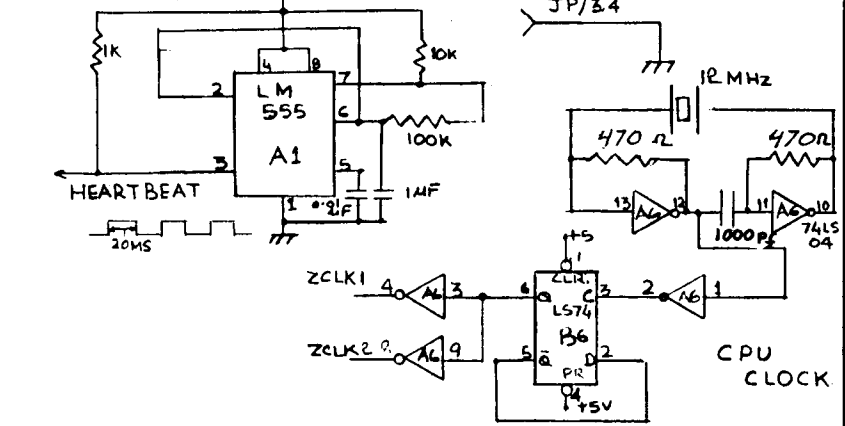
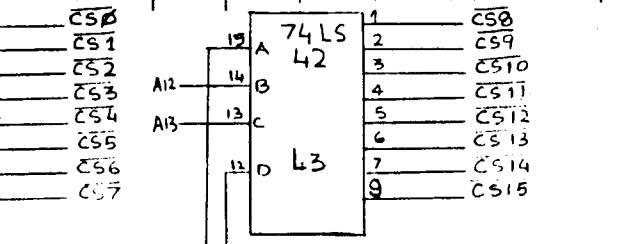
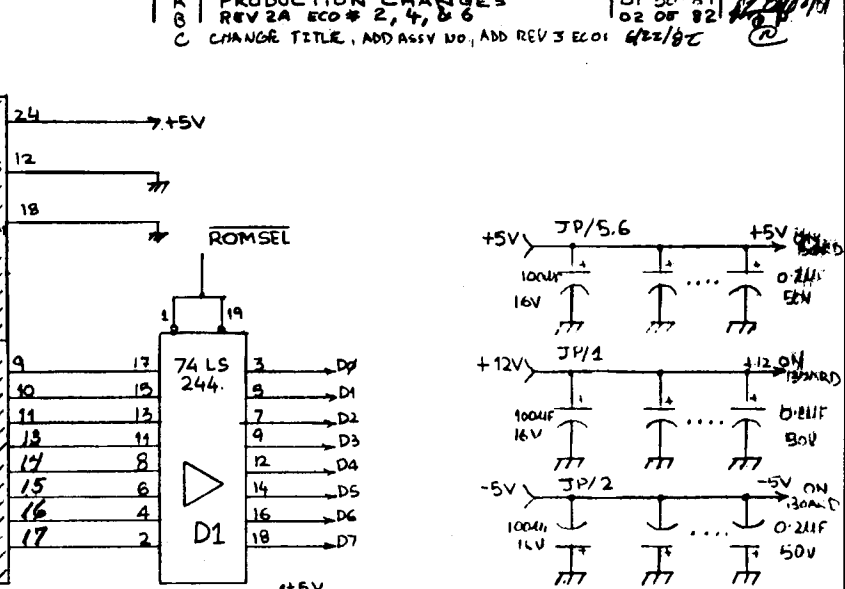
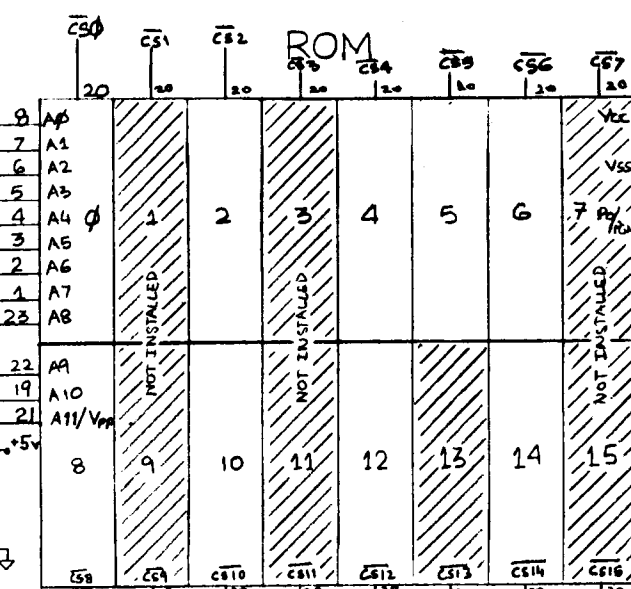

TOLERANCES UNLESS OTHERWISE SPECIFIED FRACTIONS DEC ANGLES * * *		PACIFIC NOVELTY MANUFACTURING MARINA DEL REY CA-90291	
APPROVALS		DATE	
DRAWN L. C. [Signature]		12/15/81	
CHECKED [Signature]		SCALE	
SIZE		DRAWING NO.	
C		ASSY, PCB, NATO CPU REV 3 05-10035-01	
DO NOT SCALE DRAWING		SHEET 1 OF 4	

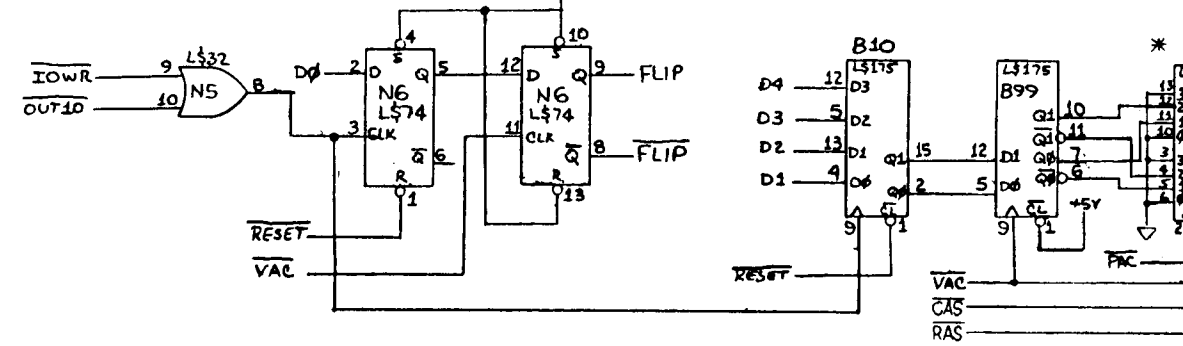
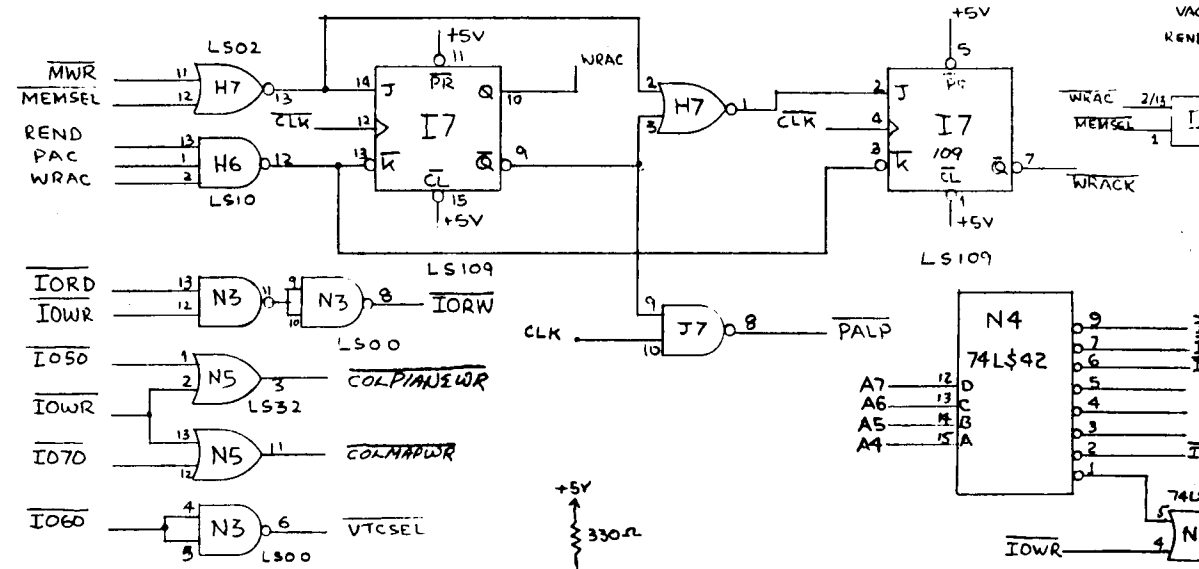
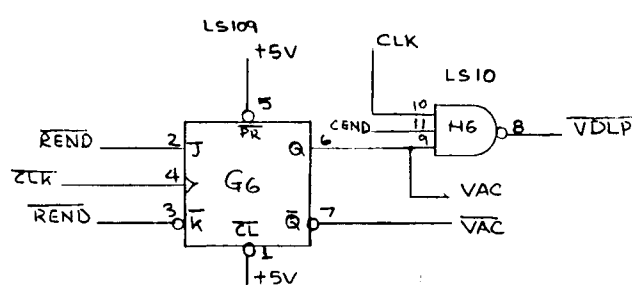
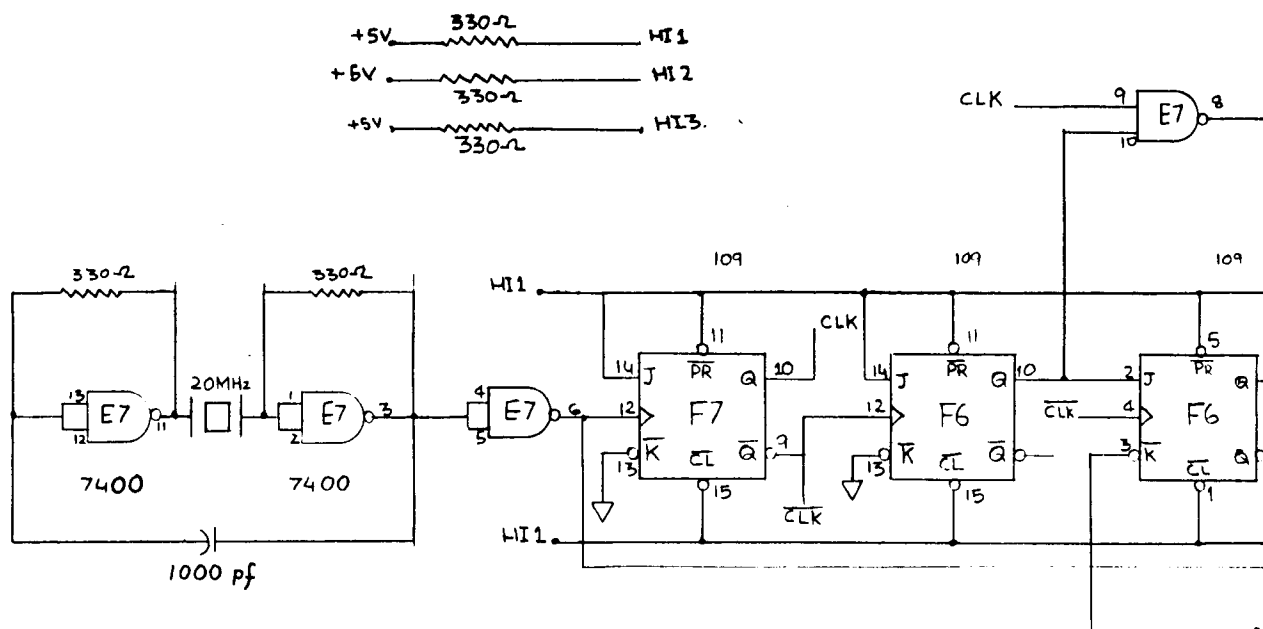

* ON SOME REV 2A BOARDS, PINS 6 & 10 (D99) ARE TO GROUND, BUT TO PINS 5 & 11 (D99) RESPE

REVISIONS		DATE	APPROVED
A	PRODUCTION CHANGES.	01 30 81.	<i>[Signature]</i>
B	REV 2A ECO #'S 2, 4, & 6	02 08 82	
C	CHANGE TITLE, ADD ASSY NO, ADD REV 3 ECOS	11/22/82	

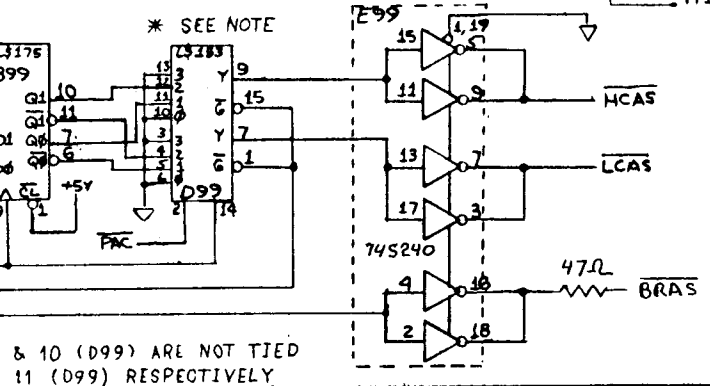
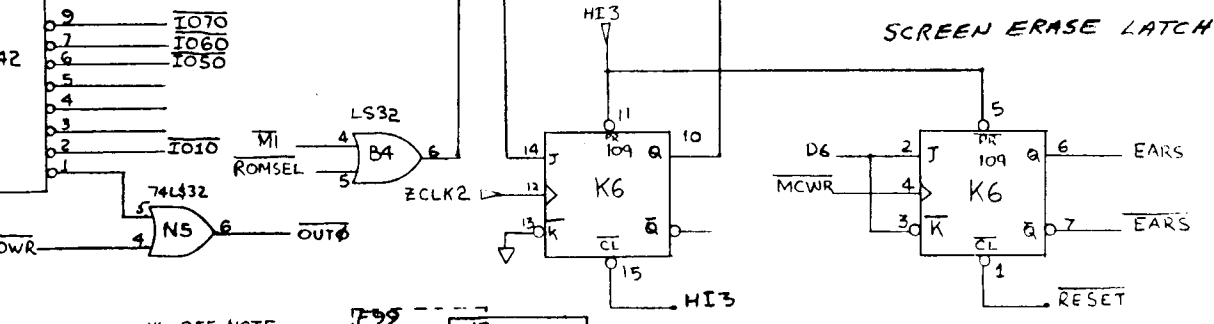
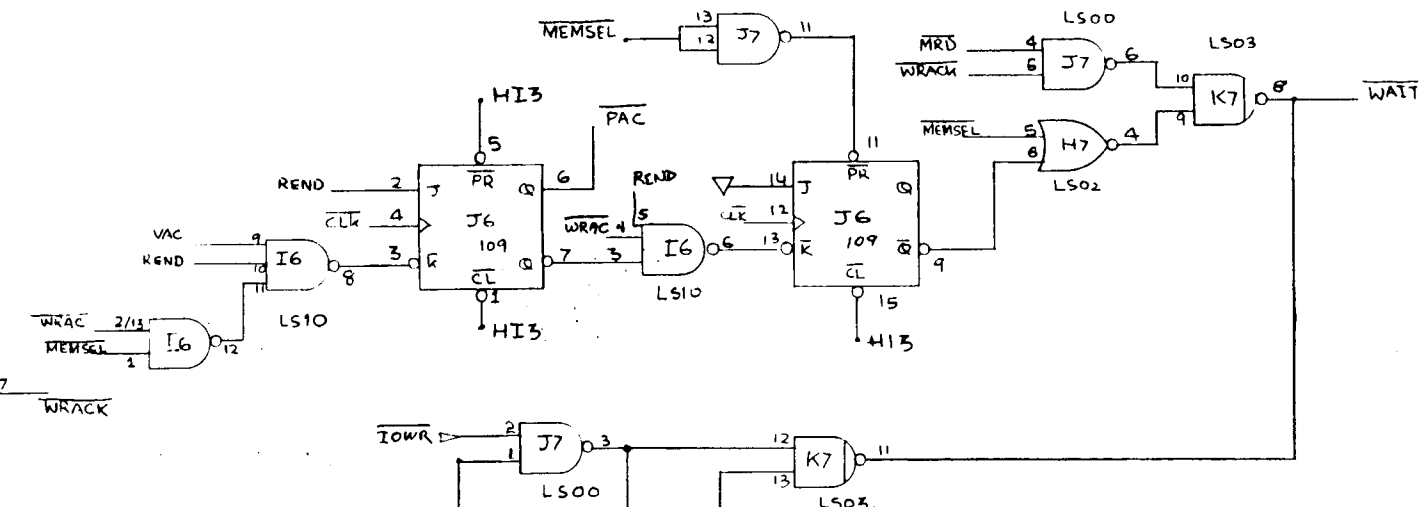
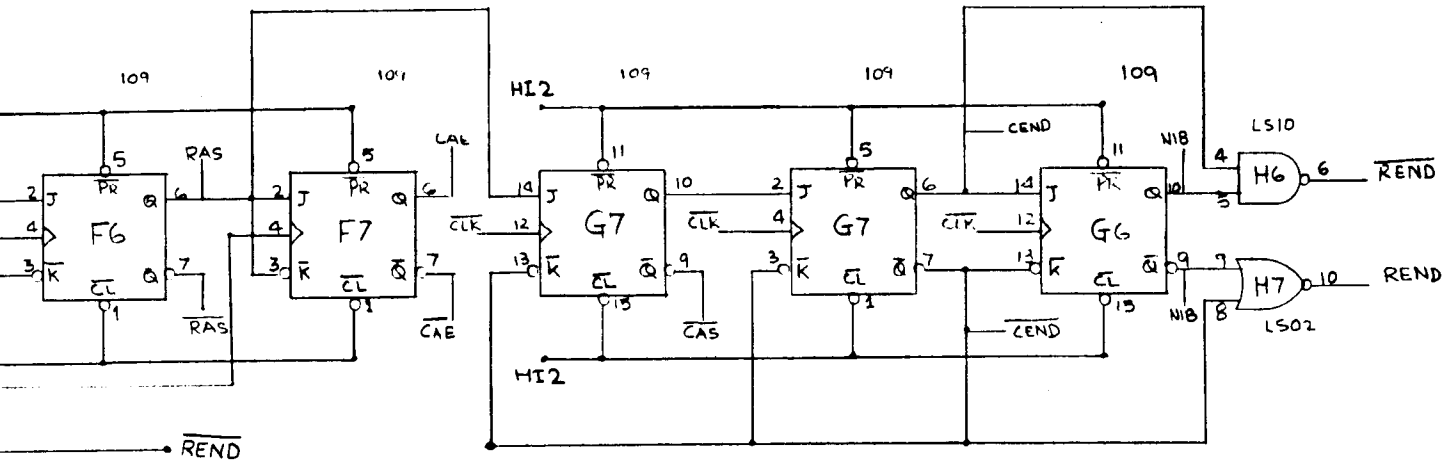
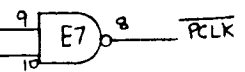

& 10 (D99) ARE NOT TIED
11 (D99) RESPECTIVELY

TOLERANCES UNLESS OTHERWISE SPECIFIED FRACTIONS DEC ANGLES		PACIFIC NOVELTY MANUFACTURING MARINA DEL-REY CA-90291	
±	±	±	±
APPROVALS		DATE	
DRAWN L. COOPER		12/15/81	
CHECKED [Signature]		SCALE	SIZE C
		DRAWING NO. 05-10035-01	
		DO NOT SCALE DRAWING	
		SHEET 2 OF 4	

LS174

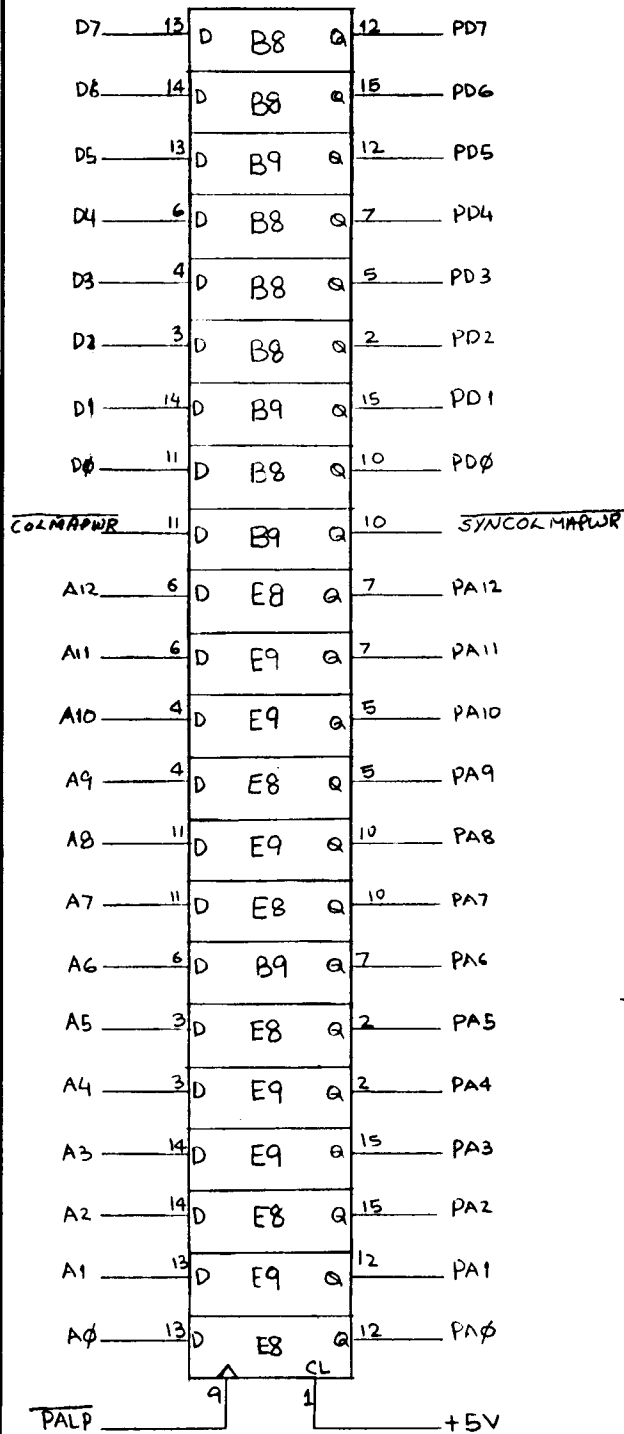

CPU: VIDEO PIPELINE REG

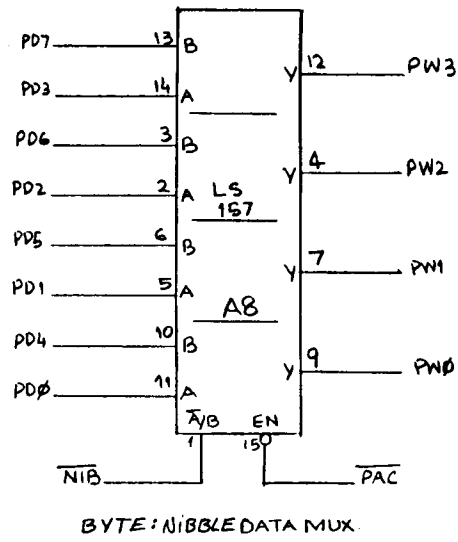

BYTE: NIBBLE DATA MUX

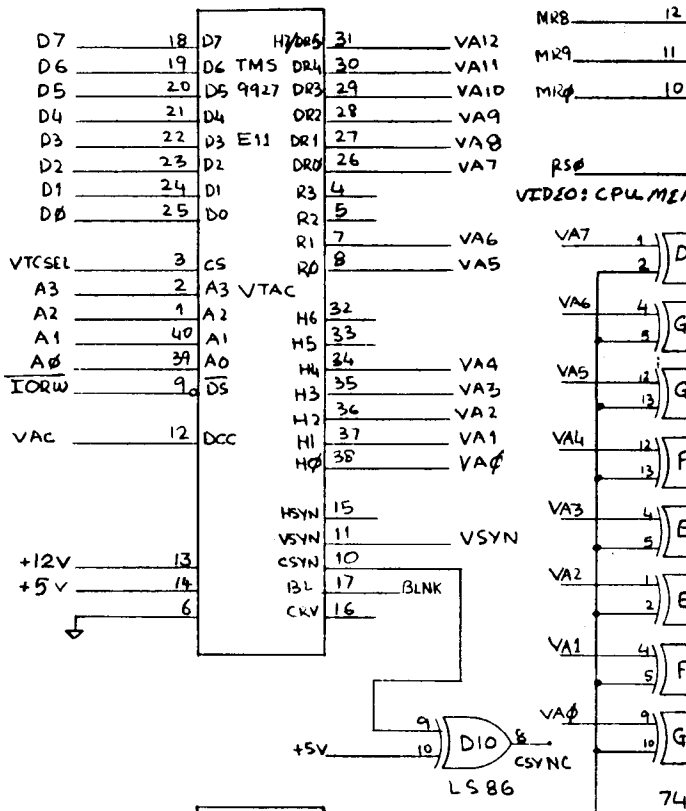

VIDEO: CPU MEM

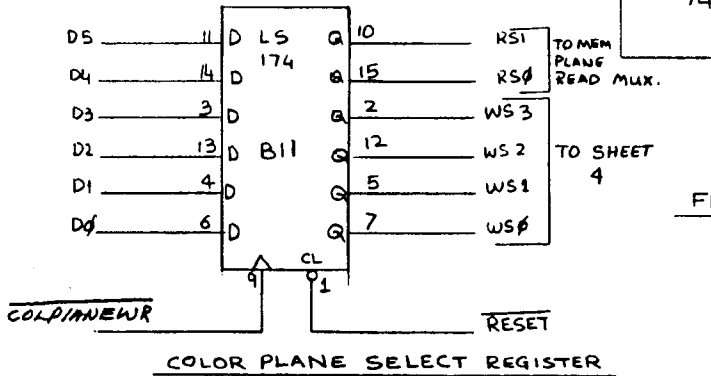

COLOR PLANE SELECT REGISTER

LTR	DESCRIPTION	DATE	APPROVED
A	PRODUCTION CHANGES	01 30 81	<i>[Signature]</i>
B	REV 2A ECO #'S 2, 4, 8, 6	02 05 82	<i>[Signature]</i>
C	CHANGE TITLE, ADD ASSY. NO, ADD REV 3 ECO:	6/22/82	<i>[Signature]</i>

74LS174

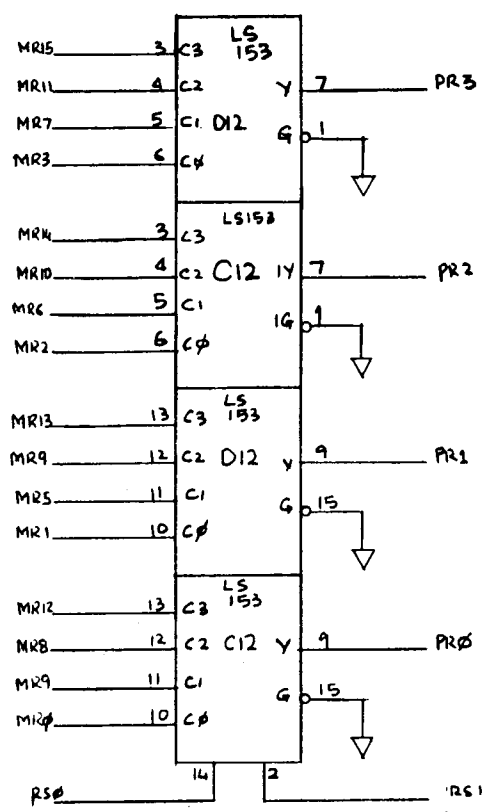

VIDEO: CPU MEMORY PLANE READ MUX

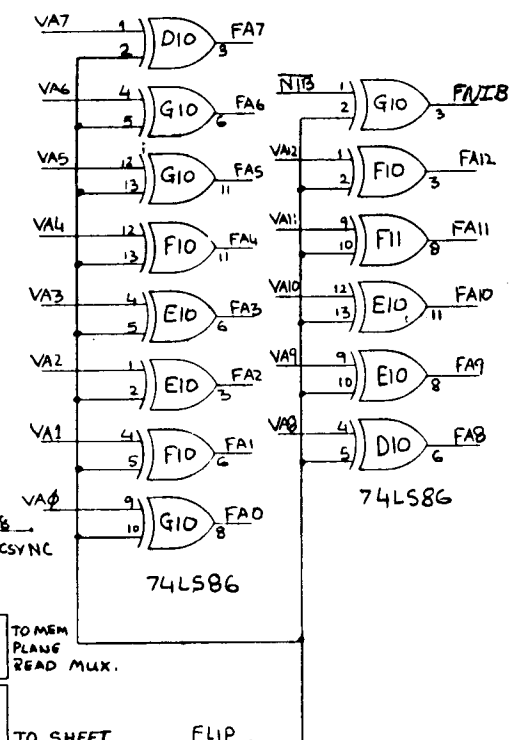

FLIP CIRCUIT

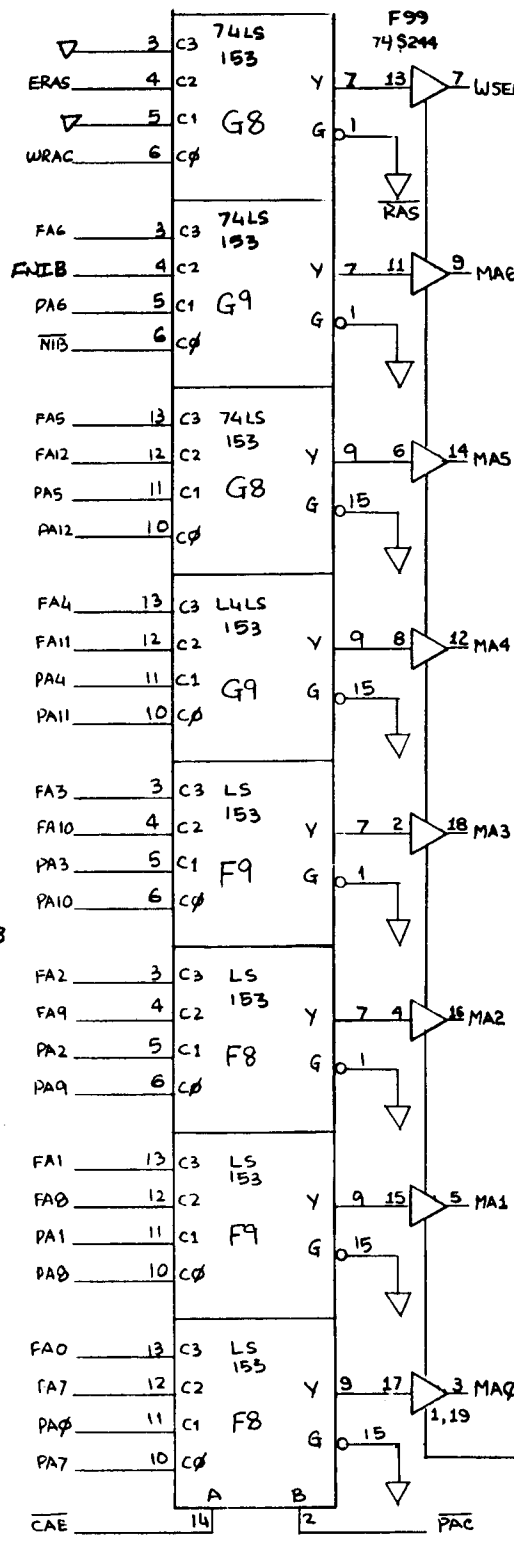

DYNAMIC ADDRESS MUX

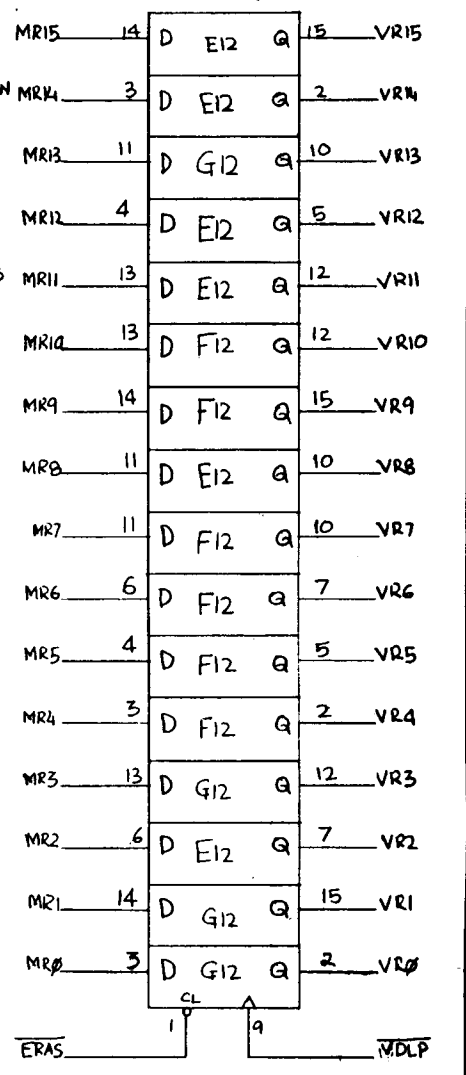

MEMORY READ PIPE LINE REGISTERS

TOLERANCES UNLESS OTHERWISE SPECIFIED		PACIFIC NOVELTY MANUFACTURING	
FRACTIONS DEC ANGLES		MARINA DELREY CA-90291	
± ± ±		ASSY. P.C.B, NATO CPU REV 3	
APPROVALS		05-10035-01	
DATE		SCALE	
DRAWN		SIZE	
CHECKED		DRAWING NO.	
DATE		C	
SCALE		DO NOT SCALE DRAWING	
DATE		SHEET 3 OF 4	

* PIN 15 IS CONNECTED TO EITHER HCAS OR LCAS
SEE RAM MATRIX TABLE FOR PHYSICAL LOCATION
OF MEMORY CHIPS ON BOARD.

SYNCO MAPWR

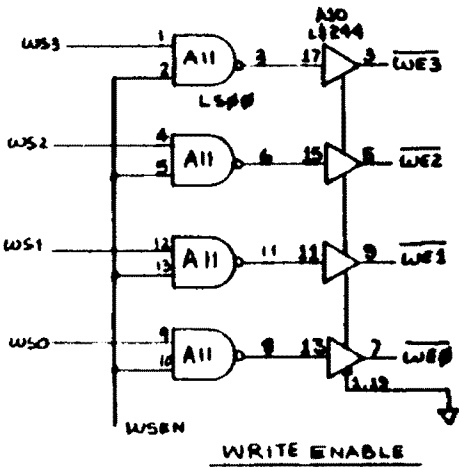
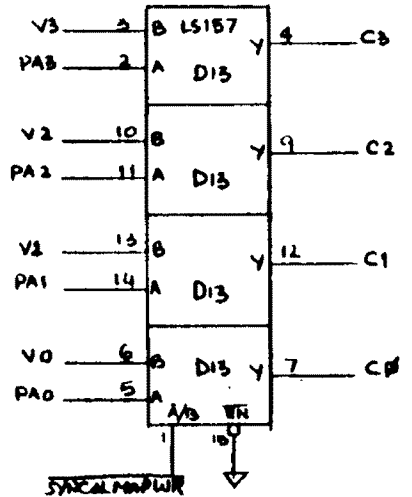
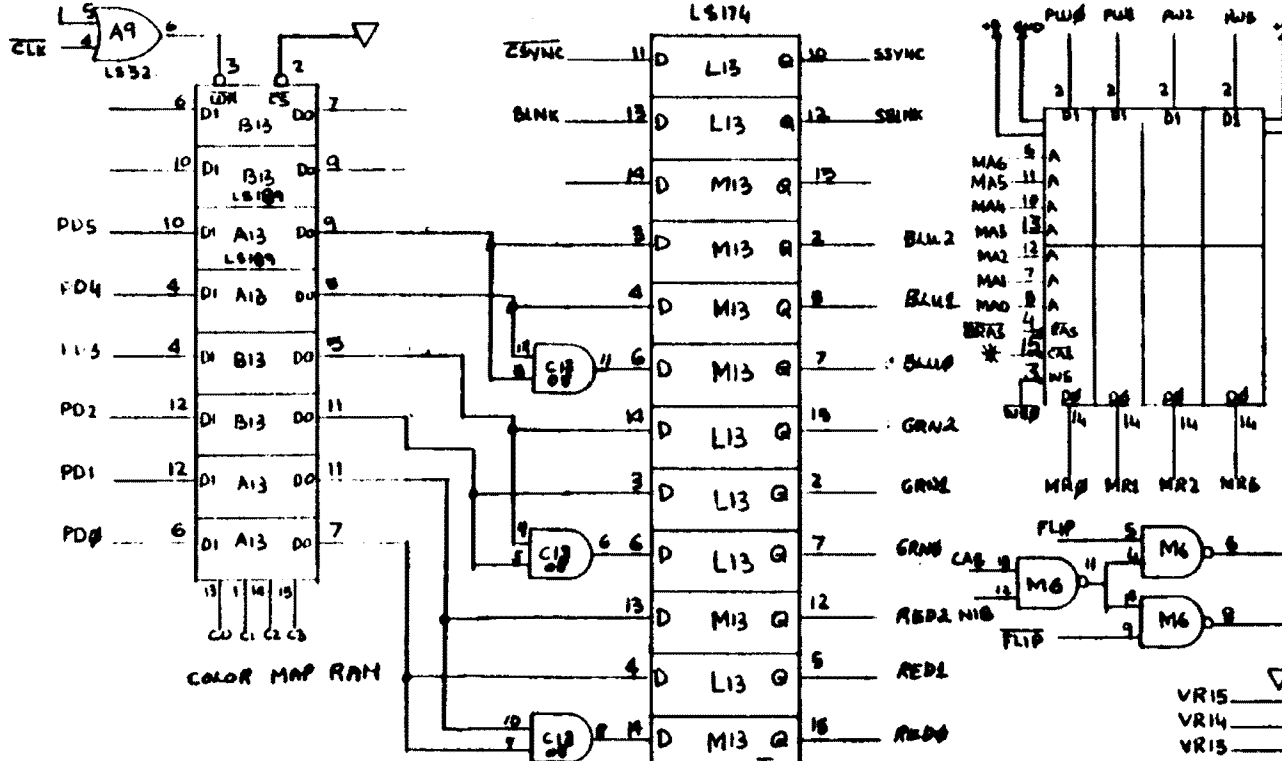

RAM MATRIX TABLE

9	8	7	6	5	4	3	2	1
0 HCAS	0 LCAS	0 LCAS	0 HCAS					
1 HCAS	1 LCAS	1 LCAS	1 HCAS					
2 HCAS	2 LCAS	2 LCAS	2 HCAS					
3 HCAS	3 LCAS	3 LCAS	3 HCAS					
4 HCAS	4 LCAS	4 LCAS	4 HCAS					
5 HCAS	5 LCAS	5 LCAS	5 HCAS					
6 HCAS	6 LCAS	6 LCAS	6 HCAS					
7 HCAS	7 LCAS	7 LCAS	7 HCAS					

NUMBERS ARE MR (DATA BITS).
TABLE IS SET UP FOR REFERENCE
WITH CPU POWER CABLE TO REAR.

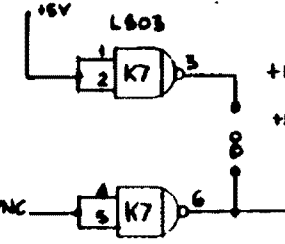

EITHER HCAS OR LCAS,
PHYSICAL LOCATION
D.

VIDEO RAM

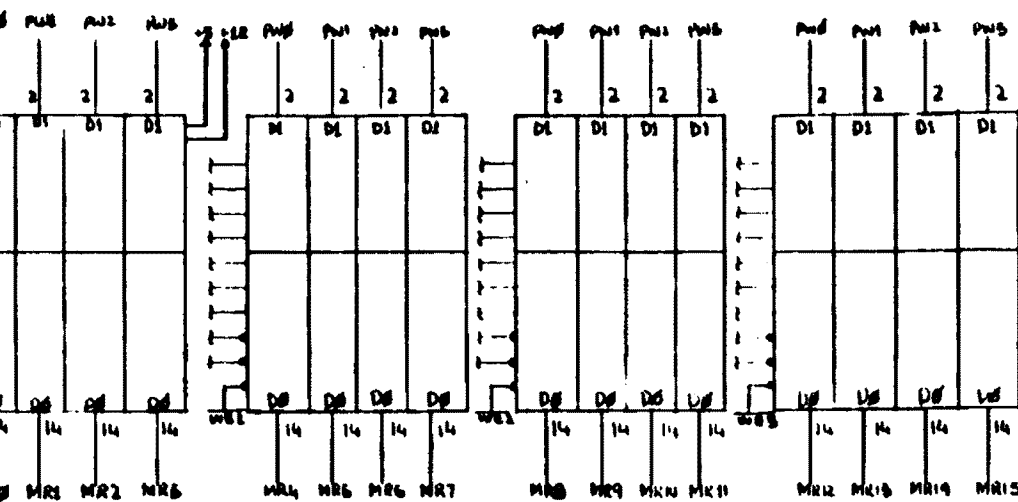

BLUE, GREEN & RED OUTPUTS

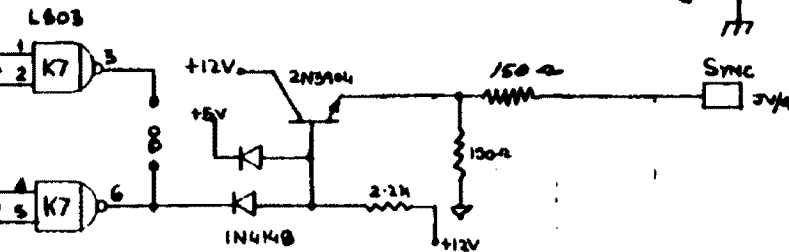
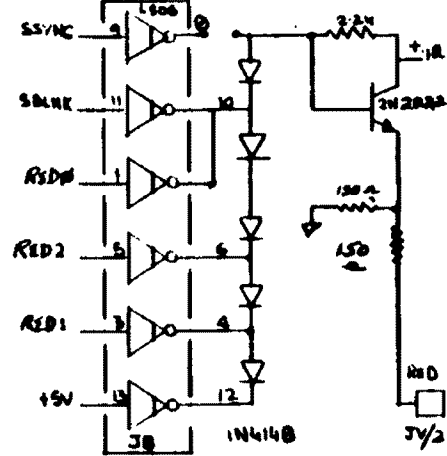
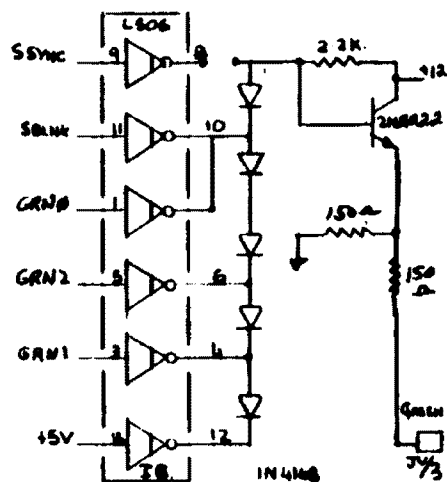
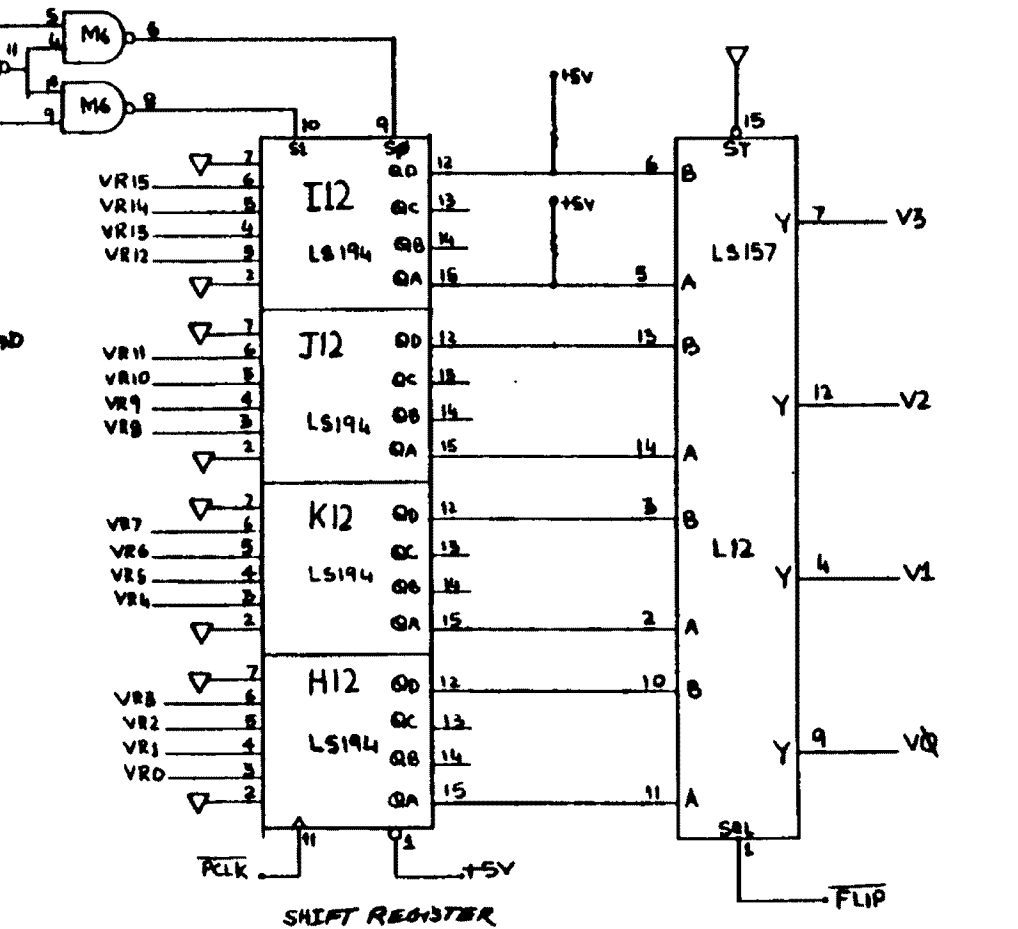
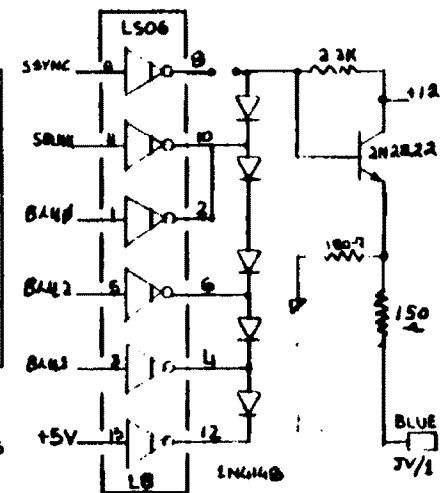

TOLERANCES UNLESS OTHERWISE SPECIFIED		PACIFIC NOVELTY MANUFACTURING	
FRACTIONS DEC ANGLES		MARINA DEL REY CA. 90292	
2	2	ASSY, P.C.B., NATO CPU REV 3	
2	2	05-10035-01	
APPROVALS	DATE	SCALE	SIZE DRAWING NO
DRYAN	05/16/81		C
CHANDALL			
DO NOT SCALE DRAWING		SHEET 4 OF 4	

INSTRUCTIONS ON INSTALLING BUILT-IN SPEED-UP KIT FOR NATO DEFENSE

The Nato Defense game which you have purchased has a built in 'speed-up' kit already in it. It is very simple to install. This change gives the player, completely new mazes to clear.

To change your game, you will have to pull out a total of four ROM (Read Only Memories) and change their positions. These ROM's are about 1 1/4" by 1/2" in size and have 24 pins on them. Note that each ROM has an identification label which identifies which position it is supposed to go into when shipped from the factory.

You can pull out the ROM's by inserting a screwdriver between the bottom of the ROM and the black plastic socket holding it, and prying it out (it does not take much force).

To insert the ROM's in their new positions note that the notch on the ROM (at the center top of the part) is pointing toward the top of the board. Make sure that all 24 pins are in the socket. Now press the ROM into the socket (it should go in without bending any pins).

Look at the COPROCESSOR board (the top board) and find the following ROM's:

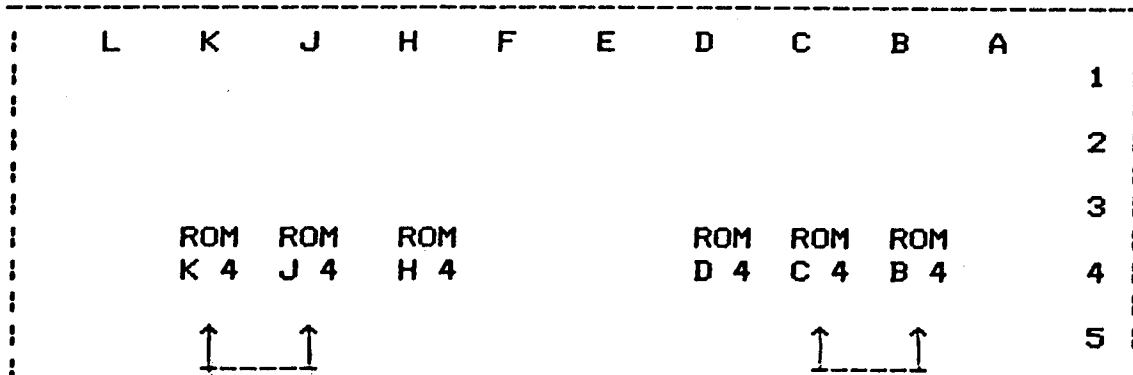

To change your game:

- Exchange ROM K4 with ROM J4
- Exchange ROM C4 with ROM B4

So ROM K4 goes in socket J4 and ROM J4 goes in socket K4 and ROM C4 goes in socket B4 and ROM B4 goes in socket C4.

That's all there is to it. Note that when you run your diagnostics, the CHECKSUMS for J4, K4, C4 and D4 will be different - this is normal. The numbers displayed will correspond to the numbers listed (on the line just before the bottom) on the label pasted to the top of the ROM's occupying the sockets.