

GENERAL INSTRUCTIONS

FOR

MS.PAC-MAN

INSTALLATION

1. Unlock and open the coin box door.
2. Remove four (4) "CABINET LEVELING LEGS" from inside the coin box.
3. Tip the cabinet to the side and remove the shipping cleats from its bottom.
 - ° Locate the threaded holes - one in each corner - and install the "CABINET LEVELING LEGS" in them.
 - ° Level the cabinet.
 - ° When finished, the cabinet should be stable in the upright position.
4. Plug the game into a **standard** A.C. wall outlet **ONLY** .

-----WARNING-----

Game **MUST** be properly grounded.

5. The power ON/OFF switch is located:
 - ° UPRIGHT MODEL: On top of the cabinet toward the back.
 - ° MINI MODEL: In the center of the cabinet back just below the rear access door.
 - ° COCKTAIL TABLE MODEL: Underneath the cabinet on Player No. 2's side.

LINE VOLTAGE SAFETY INTERLOCK SWITCHES

Line voltage SAFETY INTERLOCK SWITCHES have been provided for your protection. The locations of these SAFETY INTERLOCK SWITCHES are:

1. UPRIGHT MODEL: Inside the rear of the cabinet on the right side of the rear access door.

2. MINI MODEL: Inside the rear of the cabinet on the right side of the rear access door.
3. COCKTAIL TABEL: Inside the cabinet on the hinge side of the coin door.

When the cabinet access door(s) are secured in place, the SAFETY INTERLOCK SWITCH plunger(s) are in a fully depressed condition. The game circuit can function normally.

When any cabinet access door(s) are opened, the SAFETY INTERLOCK SWITCH plunger(s) are in a partially extended condition. This isolates the game circuit from the line voltage.

To restore power to the game circuit with the access door(s) open, gently pull the SAFETY INTERLOCK SWITCH plunger(s) out to the fully extended condition. **THIS IS TO BE USED FOR SERVICING THE GAME ONLY!**

SELF-TEST

A slide switch is provided to make the game run a "Self-Test" on itself. The SELF-TEST SWITCH is located on the right hand side of the coin door frame just inside the cabinet.

To put the game into the Self-Test mode; turn the power on and slide the SELF-TEST SWITCH to the ON position.

When in the Self-Test mode, the monitor screen will display the results of certain test functions it has run on itself. (These will be discussed in more detail later.)

TO SERVICE THE CONTROL PANEL(S)

1. UPRIGHT MODEL:

- ° The control panel is held in place by three latches, one on the left side, one on the right side, and one in the center of the front of the cabinet.

They are spring loaded to provide constant positive pressure on their latch plates.

They can be reached through the coin door **AFTER turning power to the game off.**

To release the latches, lift up and toward the center of the control panel.

Once they are released, unhook them from their latch plates.

- ° To remove the control panel:

Raise it up and tilt it toward you until you can see the cable behind it.

Cradling the control panel between yourself and the cabinet, disconnect it from its cabling.

- ° The control panel is now free and can be removed.

2. MINI MODEL:

- ° The control panel is held in place by two latches, one on the right side and one on the left side of the cabinet.

They are spring loaded to provide constant positive pressure on their latch plates.

They can be reached through the coin door **AFTER turning power to the game off.**

To release the latches, lift up and toward the center of the control panel.

Once they are released, unhook them from their latch plates.

- ° To remove the control panel:

Raise it up and tilt it toward you until you can see the cable behind it.

Cradling the control panel between yourself and the cabinet, disconnect it from its cabling.

The control panel is now free and can be removed.

3. COCKTAIL TABLE MODEL:

- ° Each control panel is held in place by several screws, two on the inside of the cabinet and three along the bottom edge of the control panel.

Turn the power off to the game.

Open the coin box door and release the two latches on the inside of the cabinet up next to the table top.

CAUTION: The right hand latch is very close to the **HIGH VOLTAGE** on the monitor. **BE CAREFUL!!**

Once they're released, unhook them from their latch plates.

Grasp the table top in the center above the coin door lifting up and to the side to tilt it open.

CAUTION: Due to the weight of the monitor, **EXTREME CARE MUST** be taken when opening the cabinet.

Remove the screws which secure the control panel in place.

- ° To remove the control panel(s):

Disconnect it from its cabling.

The control panel is now free and can be removed.

SPECIAL NOTE: TO REINSTALL ANY OF THE ABOVE REMOVED ITEMS, REVERSE THE PROCEDURE YOU USED TO REMOVE IT.

REMOVAL OF THE MAIN-DISPLAY-GLASS AND/OR THE T.V. BEZEL ASSEMBLY

1. UPRIGHT MODEL:

NOTE: To do this, the latches which secure the control panel **MUST** be released. The control panel need not be removed. See the "UPRIGHT MODEL" procedure.

- ° **Turn the power to the game off** and remove the rear access door.
- ° Remove the screws from the glass support bracket and lift it out the back of the cabinet.
- ° Grasp the main-display-glass in the top center, lift up slightly and pull it out the rear of the cabinet.
- ° Loosen the screws which secure the T.V. bezel-glass-clamps in place.

Move the clamps to the side and the bezel glass may be removed.

Remove the above mentioned screws and the bezel with four bezel-glass-clamps may be removed.

- ° To reinstall the T.V. bezel assembly and the main-display-glass, reverse this procedure.

2. MINI MODEL:

NOTE: In order to do this, the control panel **MUST** be removed first. See the "MINI MODEL" procedure.

- ° **Turn the power off to the game** and remove the control panel.
- ° Remove the screws which secure the glass clamping plate.
- ° Lift out the glass clamping plate. This frees the main-display-glass so in can be lifted up.
- ° By putting your finger in the hole in the middle of the main-display-glass support, you can lift it up and out.

- ° Remove the screws which secure the T.V. bezel assembly and lift it out.

NOTE: Use the hole in the center of the main-display-glass support to grasp it.

- ° Reverse this procedure to reinstall the T.V. bezel assembly and the main-display-glass.

3. COCKTAIL TABLE MODEL:

NOTE: This may be done with the table top in the open or the closed position. If you decide to open the table top, **TURN THE POWER TO THE GAME OFF FIRST.**

- ° Remove the screws which secure the table top glass clamps in place.
- ° Remove the table top glass.
- ° Lift out the T.V. bezel assembly.
- ° To reinstall the T.V. bezel assembly and the table top glass, reverse this procedure.

VOLUME CONTROL POT

The volume control pot is located on the Main Game Logic Board in the top right hand corner. There is only one pot. For adjustment, it may be reached through the rear access door on the UPRIGHT and MINI models. On the COCKTAIL TABLE models, you will have to open the table top to reach it.

To make the sounds louder, turn the pot clockwise as you face it (↷).

To make the sounds less loud, turn the pot counterclockwise as you face it (↶).

SELF-TEST

The Self-Test mode is a special mode for checking game switches and computer functions. It is the easiest and best way to check for proper operation of the entire game.

NOTE: Putting the game into Self-Test will cause it to erase any CREDITS on the game from its memory.

You may begin a Self-Test at any time by sliding the Self-Test switch to the "ON" position after the power to the game is on. When this is done, the game will react as follows:

1. First, you will see random colored parts of the picture, then a moving pattern of white letters and numbers followed by moving multicolored patterns on the screen.
2. Immediately following this, a rightside up test display is shown on the monitor screen. This will remain until you set the Self-Test switch back to the "OFF" position. This test display is shown below.

SELF - TEST DISPLAY
AND BOARD LOCATION COORDINATES

MEMORY OK or (M-Rom-1 / Bad C Ram-0 / Bad W Ram-1 / etc.)

*1 COIN *1 CREDIT
BONUS *15000
MS. PAC-MEN *3
UPRIGHT or (TABLE)

* = switch selectable

3. If a bad ROM or RAM chip is found by the games internal check system during the Self-Test, the game indicates this to you by showing the location code of the bad chip(s) in place of the "MEMORY OK" message. The following table translates the chip location codes into actual positions on the game logic P.C. Board.

DISPLAY	DESCRIPTION
MEMORY OK	All RAMs are good.
BAD V RAM-0	RAM located on Logic PC board at position 4K is bad.
BAD V RAM-1	RAM located on Logic PC board at position 4N is bad.
BAD C RAM-0	RAM located on Logic PC board at position 4L is bad.
BAD C RAM-1	RAM located on Logic PC board at position 4P is bad.
BAD W RAM-0	RAM located on Logic PC board at position 4M is bad.
BAD W RAM-1	RAM located on Logic PC board at position 4R is bad.
MEMORY OK	All ROMs are good.
M-ROM-0	ROM located on Logic PC board at position 6E is bad.
M-ROM-1	ROM located on Logic PC board at position 6F is bad.
M-ROM-2	ROM located on Logic PC board at position 6H is bad.
M-ROM-3	ROM located on Logic PC board at position 6J is bad.

4. The detection of bad components on the Auxiliary Logic PC Board is not quite as simple as is the case for the Main Logic PC Board. The following table lists the components that are on this Auxiliary PC Board and what symptoms they will cause to appear on the monitor when each is bad.

BAD COMPONENT	SYMPTOM DISPLAYED ON MONITOR (<u>GAME IS NOT IN SELF-TEST</u>)
Z-80 CPU	<u>STATIONARY color garbage (parts of pictures)</u> CPU located on Auxiliary PC board at position U4
E-ROM-0	<u>Game goes through warm-up routine over & over & over---</u> ROM located on Auxiliary PC board at position U5
E-ROM-1	<u>Game goes through warm-up routine over & over & over---</u> ROM located on Auxiliary PC board at position U6
E-ROM-2	<u>FLASHING color garbage (parts of pictures)</u> ROM located on Auxiliary PC board at position U7

- - -BAD COMPONENT/SYMPTOM TABLE CONTINUED- - -

BAD COMPONENT	SYMPTOM DISPLAYED ON MONITOR (<u>GAME IS NOT IN SELF-TEST</u>)
CUSTOM CHIP CG-820	Monitor screen reads out "ROM 0" With game in Self-Test - Screen reads "BAD ROM 0" CG-820 located on Auxiliary PC board at position U0
CUSTOM CHIP CG-821	Monitor screen displays FLASHING color garbage (parts of pictures) CG-821 located on Auxiliary PC board at position U1
CUSTOM CHIP CG-822	Screen display is same as for CG-821 With game in Self-Test - Screen reads out UPSIDEDOWN "BAD W RAM-0" CG-822 located on Auxiliary PC board at position U2
CUSTOM CHIP CG-823	Screen display is same as for CG-821 CG-823 located on Auxiliary PC board at position U3

5. To check your game function switches and buttons (coin counter switches, TEST CREDIT button, 1 PLAYER and 2 PLAYER buttons): activate each one while the game is in the Self-Test mode. You should hear a game sound for each activation. If you do not hear it, the switch/button is either not working, miswired, or disconnected. Check it out thoroughly.
6. When finished with the Self-Test mode, slide the Self-Test switch back to the "OFF" position.
 - ° A cross hatch pattern appears on the monitor screen for about 1 to 2 seconds.
 - ° If you wish to keep this test pattern on the monitor screen for further use, slide Self-Test switch to the "ON" position after the cross hatch pattern appears and before it disappears.
 - ° When finished with the cross hatch pattern, set the Self-Test switch to the "OFF" position.
 - ° Normal game functions will now return to the monitor screen.

OPTION SWITCH SETTINGS:

To change the option switch settings, you DO NOT have to take the Main Game Logic Board out of the game. They can be easily reached through the rear access door on the Upright and Mini models. On the Cocktail Table model, you do have to open the table top to reach them.

When changing any options, ALWAYS put the game into the Self-Test mode, make your changes, check the results on the monitor screen, take the game out of the Self-Test mode, and play the game to be sure the switches have worked properly and that no switches were accidentally moved that were not ment to be. (These switches are small and this can happen.)

The option switch settings and what they will make the game do are shown in the following Figure.

<u>MS. PAC-MAN</u>																																									
<u>OPTION SWITCH SETTINGS</u>																																									
////////////////////////////////////METHOD OF PLAY////////////////////////////////////																																									
FREE PLAY 1 COIN 1 PLAY 1 COIN 2 PLAYS 2 COINS 1 PLAY	<table border="1"> <thead> <tr> <th>SW#1</th> <th>SW#2</th> <th>SW#3</th> <th>SW#4</th> <th>SW#5</th> <th>SW#6</th> <th>SW#7</th> <th>SW#8</th> </tr> </thead> <tbody> <tr> <td>ON</td> <td>ON</td> <td></td> <td></td> <td></td> <td></td> <td></td> <td></td> </tr> <tr> <td>OFF</td> <td>ON</td> <td></td> <td></td> <td></td> <td></td> <td></td> <td></td> </tr> <tr> <td>ON</td> <td>OFF</td> <td></td> <td></td> <td></td> <td></td> <td></td> <td></td> </tr> <tr> <td>OFF</td> <td>OFF</td> <td></td> <td></td> <td></td> <td></td> <td></td> <td></td> </tr> </tbody> </table>	SW#1	SW#2	SW#3	SW#4	SW#5	SW#6	SW#7	SW#8	ON	ON							OFF	ON							ON	OFF							OFF	OFF						
SW#1	SW#2	SW#3	SW#4	SW#5	SW#6	SW#7	SW#8																																		
ON	ON																																								
OFF	ON																																								
ON	OFF																																								
OFF	OFF																																								
////////////////////////////////////NUMBER OF MS. PAC-MEN PER GAME////////////////////////////////////																																									
1 MS. PAC-MAN 2 MS. PAC-MEN 3 MS. PAC-MEN 5 MS. PAC-MEN	<table border="1"> <tbody> <tr> <td></td> <td>ON</td> <td>ON</td> </tr> <tr> <td></td> <td>OFF</td> <td>ON</td> </tr> <tr> <td></td> <td>ON</td> <td>OFF</td> </tr> <tr> <td></td> <td>OFF</td> <td>OFF</td> </tr> </tbody> </table>		ON	ON		OFF	ON		ON	OFF		OFF	OFF																												
	ON	ON																																							
	OFF	ON																																							
	ON	OFF																																							
	OFF	OFF																																							
////////////////////////////////////BONUS MS. PAC-MEN////////////////////////////////////																																									
BONUS MS. PAC-MAN AT 10,000 POINTS BONUS MS. PAC-MAN AT 15,000 POINTS BONUS MS. PAC-MAN AT 20,000 POINTS NO BONUS	<table border="1"> <tbody> <tr> <td></td> <td>ON</td> <td>ON</td> </tr> <tr> <td></td> <td>OFF</td> <td>ON</td> </tr> <tr> <td></td> <td>ON</td> <td>OFF</td> </tr> <tr> <td></td> <td>OFF</td> <td>OFF</td> </tr> </tbody> </table>		ON	ON		OFF	ON		ON	OFF		OFF	OFF																												
	ON	ON																																							
	OFF	ON																																							
	ON	OFF																																							
	OFF	OFF																																							
////////////////////////////////////SPECIAL FUNCTIONS////////////////////////////////////																																									
AUTOMATIC RACK ADVANCE FREEZE VIDEO (MONITOR PRESENTATION STOPS MOVING) GAME OPERATES NORMALLY	<table border="1"> <tbody> <tr> <td></td> <td>ON</td> <td>OFF</td> </tr> <tr> <td></td> <td>OFF</td> <td>ON</td> </tr> <tr> <td></td> <td>OFF</td> <td>OFF</td> </tr> </tbody> </table>		ON	OFF		OFF	ON		OFF	OFF																															
	ON	OFF																																							
	OFF	ON																																							
	OFF	OFF																																							

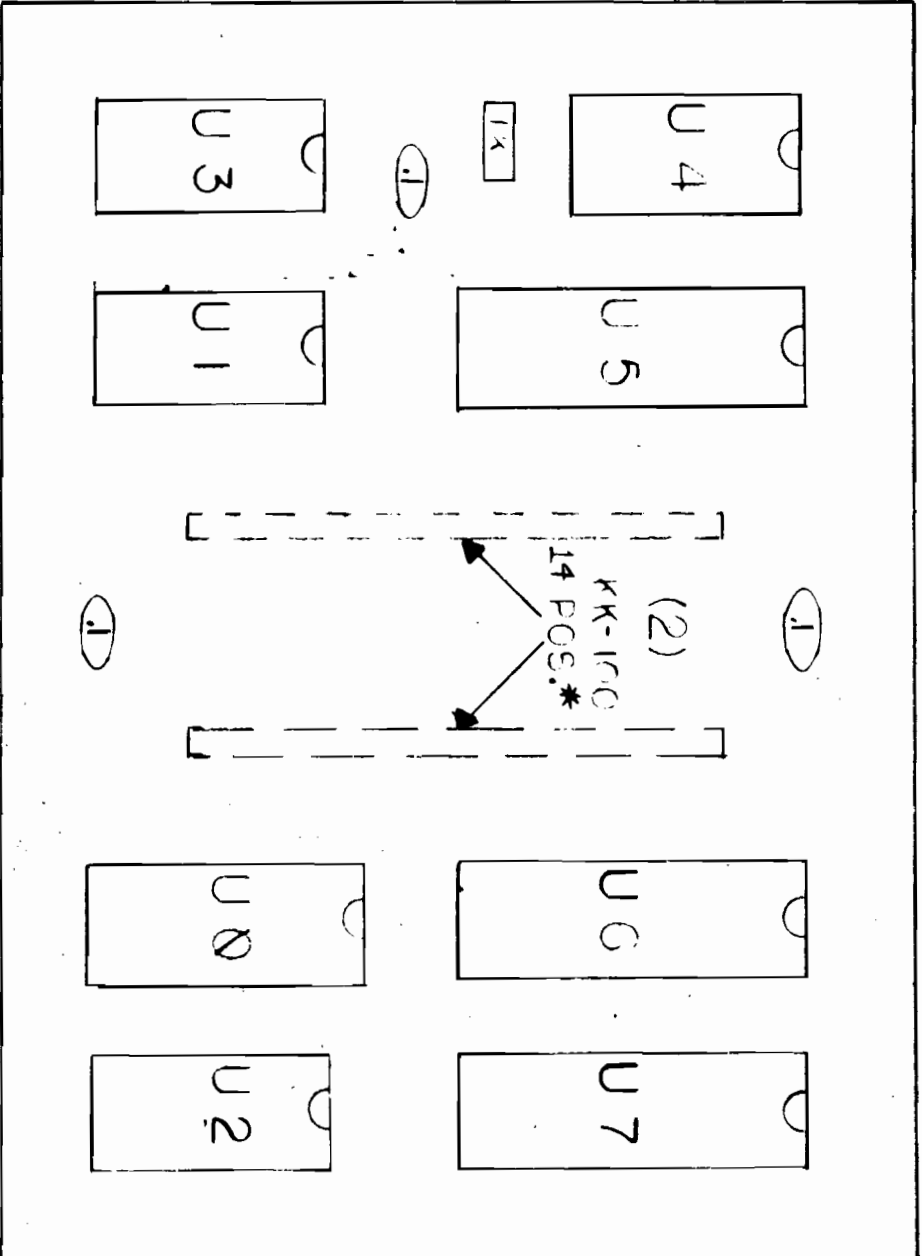

U1-74LS139
 U2-74LS02
 U3-74LS74
 U4-74LS02
 U5-74LS74
 U6-74LS244
 U7-74LS374
 U8-74LS374
 U10-1K/4W RESIS.
 U2-1MF 50V
 AX. CER.
 * MOUNTED ON
 SOLDER SIDE

M051-00932-8031

REVISIONS	

DO NOT SCALE DWG.		HEAT TREAT		SCALE		USED ON (PFC-MR/J)		MIDWAY MFG. CO.	
DIM. TOLERANCES UNLESS SPECIFIED		M.M.		FINISH		NO. REQ'D 1-PER			

CONCENTRICITY T.I.R. .003		D.M.N.		SCALE		Z-80 SYNC BUSS CONTROLLER(265)		PART NO.	
FRACTIONAL .1/64		M.M.		SCALE		COMPONENT LAYOUT		AGE 2-91383-8000	
DECIMAL .003		DATE 10-23-80		SCALE		COMPONENT LAYOUT		FRANKLIN PK. ILL.	
HOLE DIA. +.001-.000		DATE 10-23-80		SCALE		COMPONENT LAYOUT		FRANKLIN PK. ILL.	

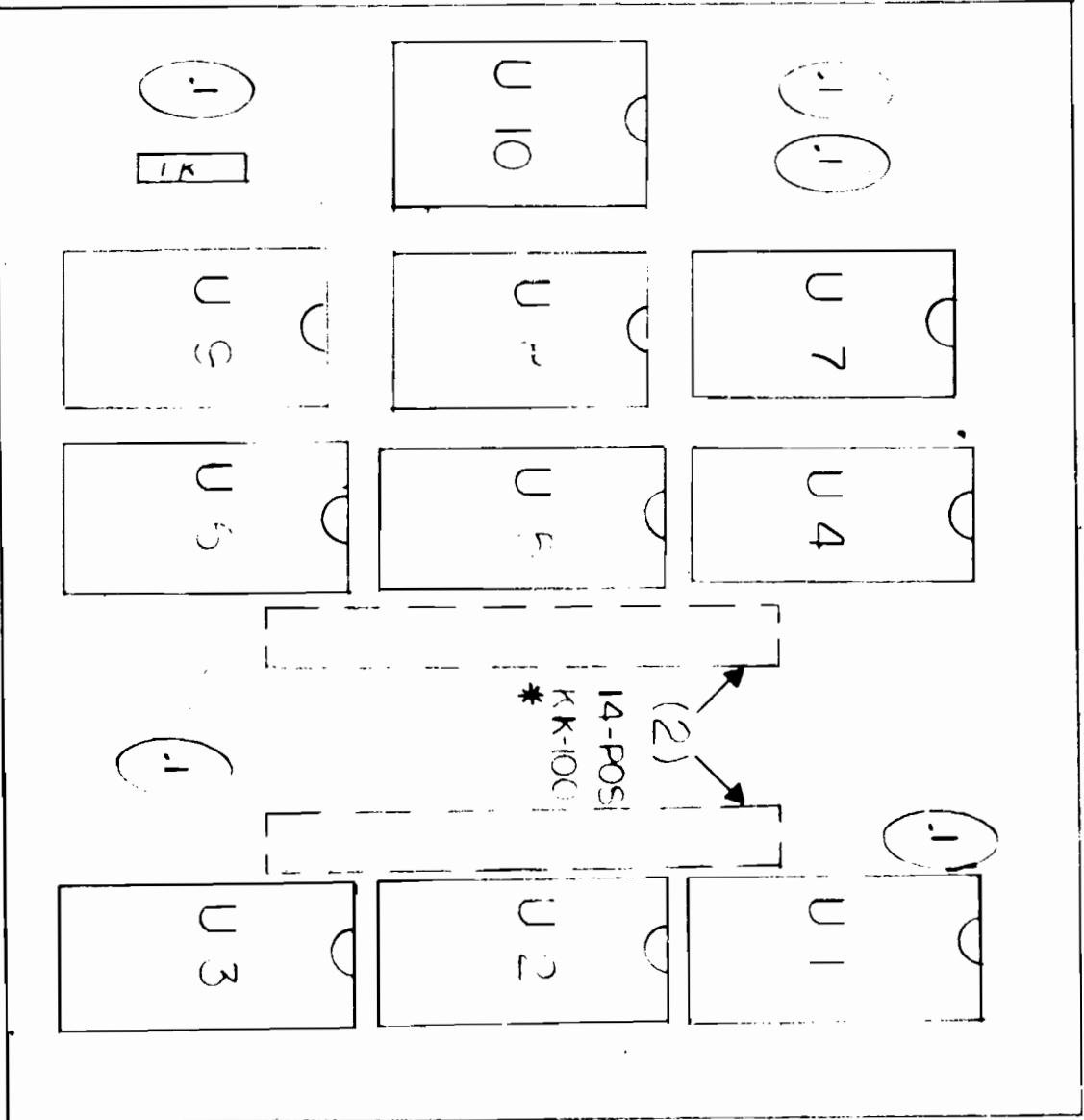

- U1, U2, U3, -74LS257
- U4, U5, U6, -74LS157
- U7, U8, U9, -74LS96
- U10 -74LS02
- .1 MF 50V - (5)
- AX CER
- 1K 1/4w - (1)
- (2) - 14-POS. K-K-100
- * MOUNTED ON SOLDER SIDE

M051-00932-B034

DO NOT SCALE DWG.

DIM. TOLERANCES UNLESS SPECIFIED	DRN.	MM
	CKD.	
CONCENTRICITY T.I.R. .003	DATE	10-27-80
FRACTIONAL .1/64		
DECIMAL .005		
HOLE DIA. +.002-.000		

HEAT TREAT

SCALE

USED ON PAC-MAN
NO. REQ'D 1-PER.

MIDWAY MFG. CO.
FRANKLIN PK. ILL.

MATL.
FINISH

V-RAM ADDRESSER (284)
COMPONENT - LAYOUT

PART NO.
A082_91384_B000

REVISIONS	

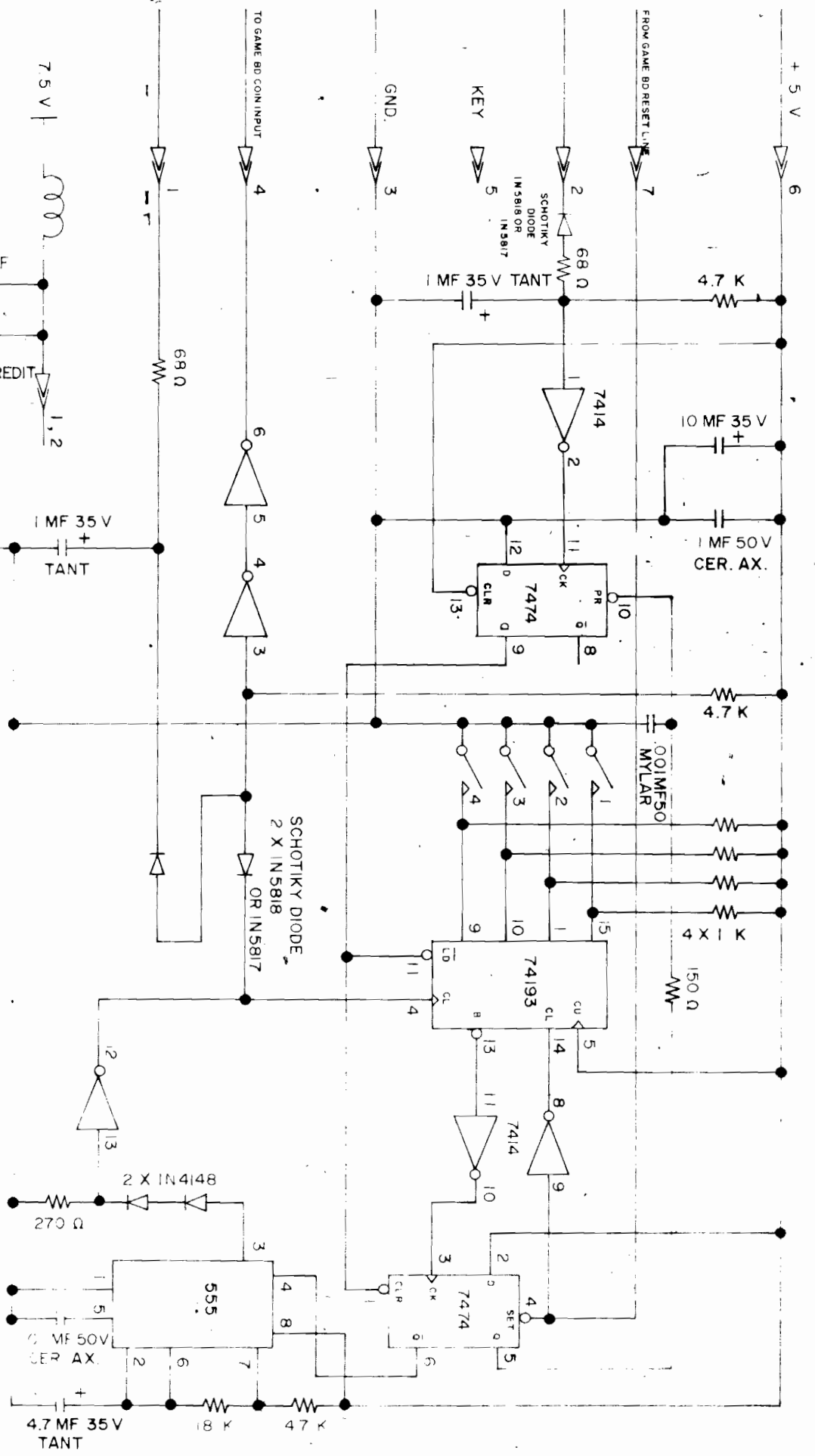

M051-00932-C029

PAC-MAN

MIDWAY MFG. CO.

SCHEMATIC DIAGRAM
CREDIT MULTIPLIER

A082 91348 C000

10/23/80

Service Set-Up Procedure

NOTE: All monitors are equipped with automatic degaussing coils which effectively demagnetize the picture tube each time the monitor is turned on. The degaussing coils will operate any time the set is turned on after having been off for at least five minutes.

The degaussing effect is confined to the picture tube since the coils are mounted on the ferrous tube shield. Should any part of the chassis or cabinet become magnetized, it will be necessary to degauss the affected area by means of a manual degaussing coil. Move the coil slowly around the CRT face area, then slowly withdraw for a distance of six feet before disconnecting the coil from the AC power supply.

Normally little, if any adjustment should be necessary. However, when a picture tube, yoke or similar component is replaced, preliminary static convergence should be done before attempting purity adjustment, and so on.

Set up should be done in a north/south direction. Horizontal and vertical centering taps should be set to the centre position if a major component has been changed.

1.0 Purity

- 1.1 Loosen yoke retaining clamp (figure 2), remove adhesive material fixing wedges to CRT. Remove wedges completely and clean off dried adhesive from picture tube and wedges.
- 1.2 A small quantity of "nail polish" has been used to lock the purity convergence rings in place. This seal must be broken with a sharp tipped instrument before any adjustments are attempted. Some models also use a locking ring at either end of the purity and convergence rings. This must be loosened before adjustments are made. It goes without saying that upon completion of all adjustments, the lock must be reset and/or a dab of paint or nail polish must be re-applied to edge of rings to prevent movement.
- 1.3 Connect an appropriate signal source, eg: Electro-home RGB generator producing a white field plus individual red, green and blue fields.
- 1.4 Bring the long and short purity tab protrusions in line with each other to obtain near-zero magnetic field (figure 4) (In some cases bring the flat and indented tabs together to obtain zero field). Protrusions can then be vertical, horizontal or at any convenient angle to start.
- 1.5 Turn off the green and blue fields and adjust setup controls to produce a red field. (See fig. 3)
- 1.6 Pull the deflection yoke back so that a red band appears in the centre of the screen.
- 1.7 Spread the tabs apart as little as necessary and rotate both rings together to center the red band horizontally on the face of the CRT (approximate). (See Fig. 5)
- 1.8 Slide the yoke towards the bell of the picture tube slowly to obtain a uniform red field (pure in color) across the entire tube face. Juggle back and forth slightly as necessary. Lightly tighten yoke retaining clamp.
- 1.9 Momentarily switch on a cross-hatch signal and rotate yoke to level the pattern on the face of CRT.
- 1.10 Return generator to regain red raster.
- 1.11 Turn off red field and check for pure field for each of the green and blue fields. Reposition yoke if necessary to obtain optimum purity on all fields.
- 1.12 Tighten yoke retaining clamp to prevent yoke shift or rotation. (Do not install wedges at this time.)

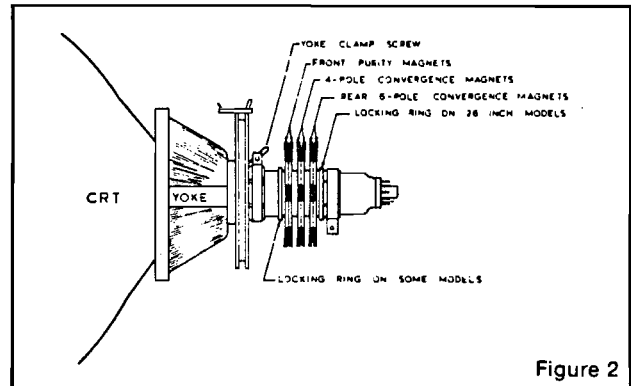

Figure 2

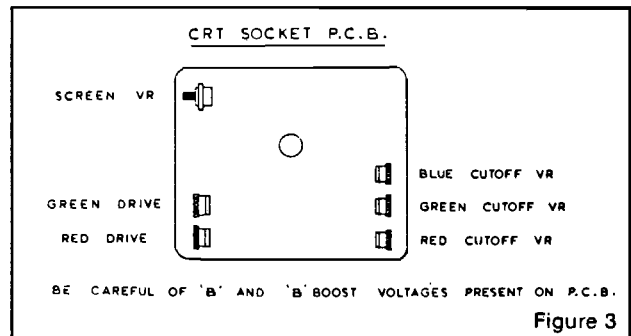

Figure 3

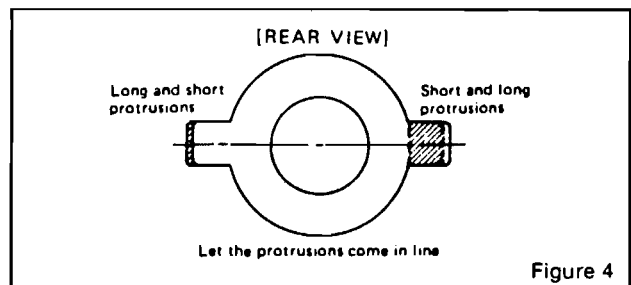

Figure 4

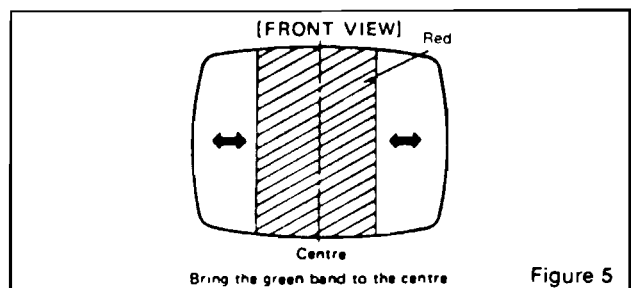
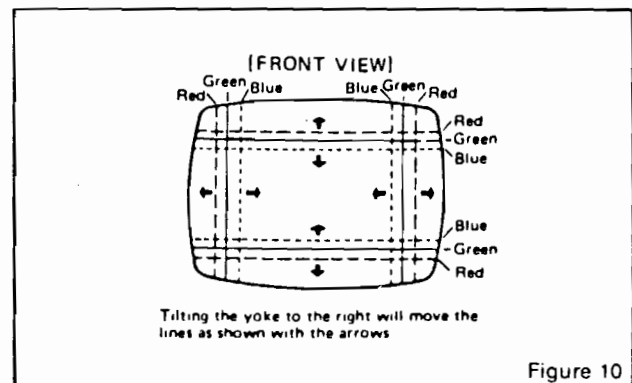
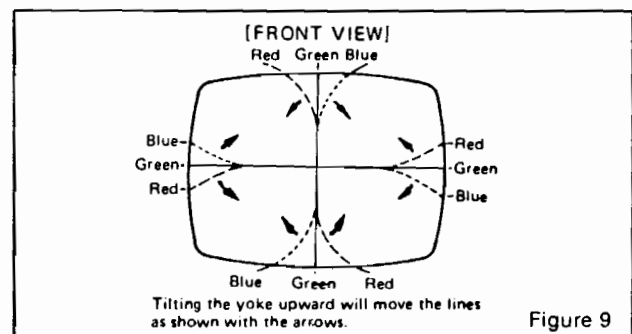
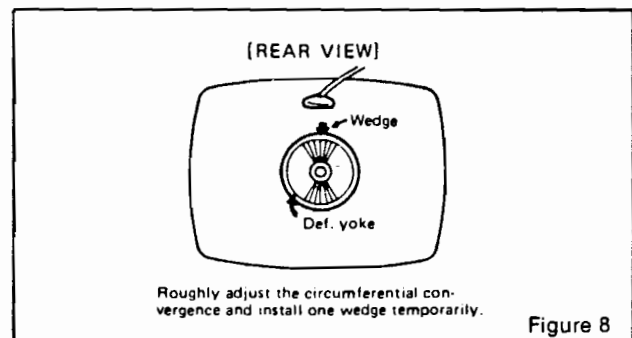
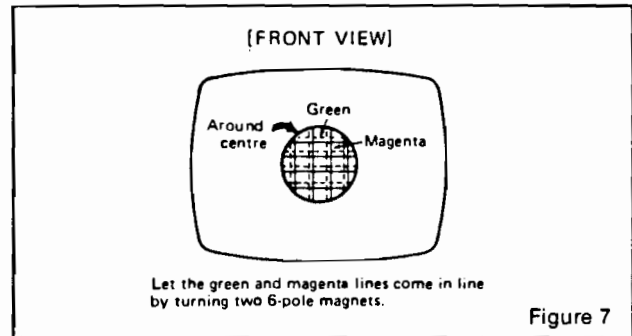
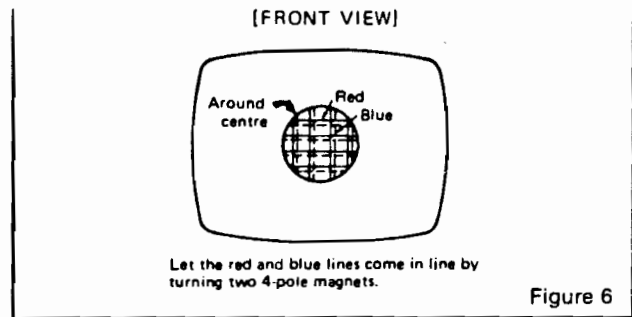

Figure 5

NOTE: Static convergence is achieved by four magnets located on the neck, nearest the base of the picture tube, Fig. 2. The middle pair of magnetic rings are adjusted to converge the blue and red crosshatch lines. The rear pair of convergence rings (closest to the base of the picture tube) are adjusted to converge the magenta (blue/red) to the green crosshatch lines. Dynamic convergence is achieved by tilting the deflection yoke up-down and left-right.

- 2.1 Ensure that the controls misadjusted during purity setup (screen, cut-off, etc.) are set to give white balance. See 3.0 below.
 - 2.2 Switch generator to the crosshatch pattern.
 - 2.3 Adjust convergence around the edges of the picture tube by tilting the yoke up-down and left-right, and temporarily install one wedge at the top of the yoke or in a more optimum position. (Figures 8, 9, 10)
 - 2.4 Turn off green input and turn on the red and blue input.
 - 2.5 Rotate the 4-pole (middle) pair of magnets as a unit to minimize separation of the red and blue crosshatch lines around the center of the screen (Figure 6). Variation of the angle between the tabs adjusts convergence of red and blue. (Tilt yoke as required to converge red and blue at the edges as in 2.3 above.)
 - 2.6 Turn on green input to obtain magenta (red/blue) and green crosshatch lines. Rotate the 6-pole (rear) pair of magnets as a unit to minimize separation of the magenta and green lines (figure 7). Vary angle between the two tabs and further rotate as a unit to finalize.
 - 2.7 When convergence of 3 colors is optimized (static in center and dynamic around edges) apply stripe of paint or nail polish to convergence magnet rings to prevent movement. If applicable, tighten locking ring carefully.
 - 2.8 Remove temporary wedge from yoke. Tilt yoke in up-down and left-right direction for best circumference convergence and install 3 wedges. (It is best to use 3 new wedges since they have adhesive backing. Simply pull off tape, slide wedge in place and press outer flap down firmly. For more permanency apply small quantity of silastic or similar material at junction of wedges and picture tube. Do not disturb while material is setting. (Order wedges by part number 39-1233-01).
- 3.0 White Balance (Grey Scale Tracking)**
Refer to figure 3. Do the following in subdued light:
- 3.1 Note this adjustment can be accomplished with no signal connected; eg: input connector open or if a signal generator is connected, switch off all 3 inputs at the generator.
 - 3.2 Set red and green drive controls to their mechanical center and turn the common G2 screen control and 3 cut-off controls to minimum (fully counterclockwise).
 - 3.3 Slowly turn up G2 screen control until the first faint color appears, then back off to edge of visibility. Do not touch the associated cut-off control - it should stay fully CCW for the remaining set-up.
 - 3.4 Slowly turn up the other two color cut-off controls in turn to match the first. This should result in the faintest grey.
 - 3.5 Turn on the signal generator with all 3 inputs on. (a crosshatch pattern would be appropriate).



- 3.6 Adjust the red and green drive controls for "neutral white" on high white picture areas. Generally these controls will be left at mech. centre.
- 3.7 Note: When monitor is re-connected with the game the screen control (G2) may require a slight adjustment to obtain proper black level. (the black portion of picture just extinguished).

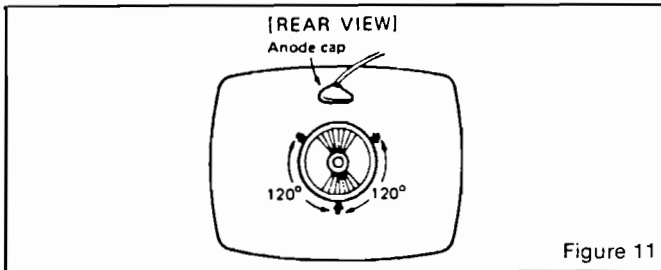

Figure 11

4.0 Power Supply

The regulated +B1 control (R909) has been factory adjusted and normally requires no adjustment. However, if any repairs have been made to the chassis it is recommended that this adjustment should be made.

- a) Allow 5 minutes to warm up.
- b) No signal applied.
- c) Connect an accurate D.C. voltmeter to TP-91 or the emitter of X04 power regulator transistor.
- d) Adjust R909 for 120V. (See fig. 1)

Note:

Should +B1 control be set too high, it may cause possible component damage. Use an accurate D.C. voltmeter to set B1 (B+).

5.0 Focus

Adjust focus control for best overall definition and picture detail an average signal applied. (Highlights should be favoured.)

6.0 Color Service Generator for G07 Monitor

Electrohome has developed a color service generator that is specifically designed for use with the G07 color data monitor. It provides the monitor with both horizontal and vertical sync, as well as the following test patterns:

- 1) Fine cross-hatch pattern
- 2) Broad bar cross-hatch pattern
- 3) Complete field

Three color selection switches, red, green and blue, provide the ability to display the above patterns in the three primary colors as well as the three secondary colors.

This product may be ordered from:

Contracts Marketing
 ELECTROHOME Electronics
 809 Wellington St. North
 Kitchener, Ontario
 Canada N2G 4J6
 Telephone: (519) 744-7111, Ext. 567

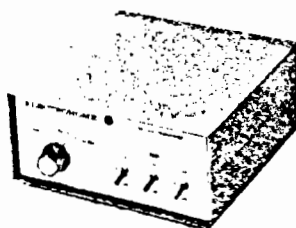

7.0 X-Ray Emission Check

- 7.1 Assure the power supply B1 is properly adjusted to 120V DC. See Item 4.0 (page 8)
- 7.2 Assure that the anode voltage does not exceed max. as per Item 2.0 page 4.
- 7.3 Assure that the high voltage hold down circuit is operating correctly. Use the following procedure.
 - a) Increase the B1 greater than 138.5V by shorting collector/emitter of the power regulator, X04.
 - b) Observe that the anode voltage (EHT) goes to 0. If the EHT does not go to 0, a fault must be located and repaired.
 - c) Remove short and set should return to normal operation. (Note, after the short is removed some monitors may not restart. In this case, remove power from monitor momentarily and normal operation will be restored.

Note:

The protector circuit consists of the components shown below in Fig. 13 with a circuit description.

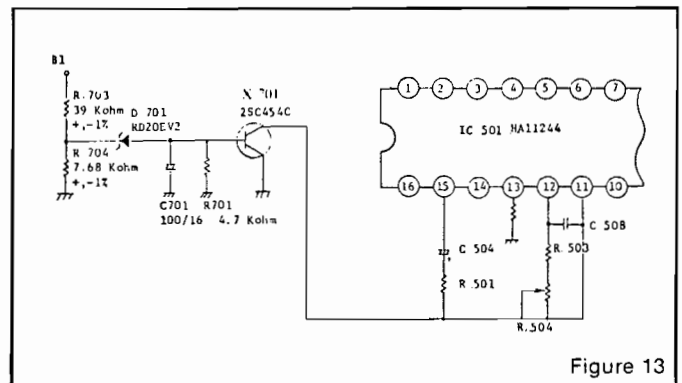

Figure 13

8.0 Circuit Diagram and Description of High Voltage Hold Down or Safety Circuit

- 8.1 Circuit Diagram of High Voltage Hold Down Circuit.
- 8.2 Operation of High Voltage Hold Down Circuit.

The high voltage hold-down circuit protects the high voltage circuit from dangerous voltage with short circuiting between emitter and collector of power-regulating transistor.

The base voltage of X701 is increased when the B1 voltage is increased more than 138.5 V DC.

When the base of X701 is increased, a short is produced by X701 between pin 11 and ground of IC 501, shutting down the horizontal osc. and high voltage.

13" COLOR MONITOR SCHEMATIC DIAGRAM

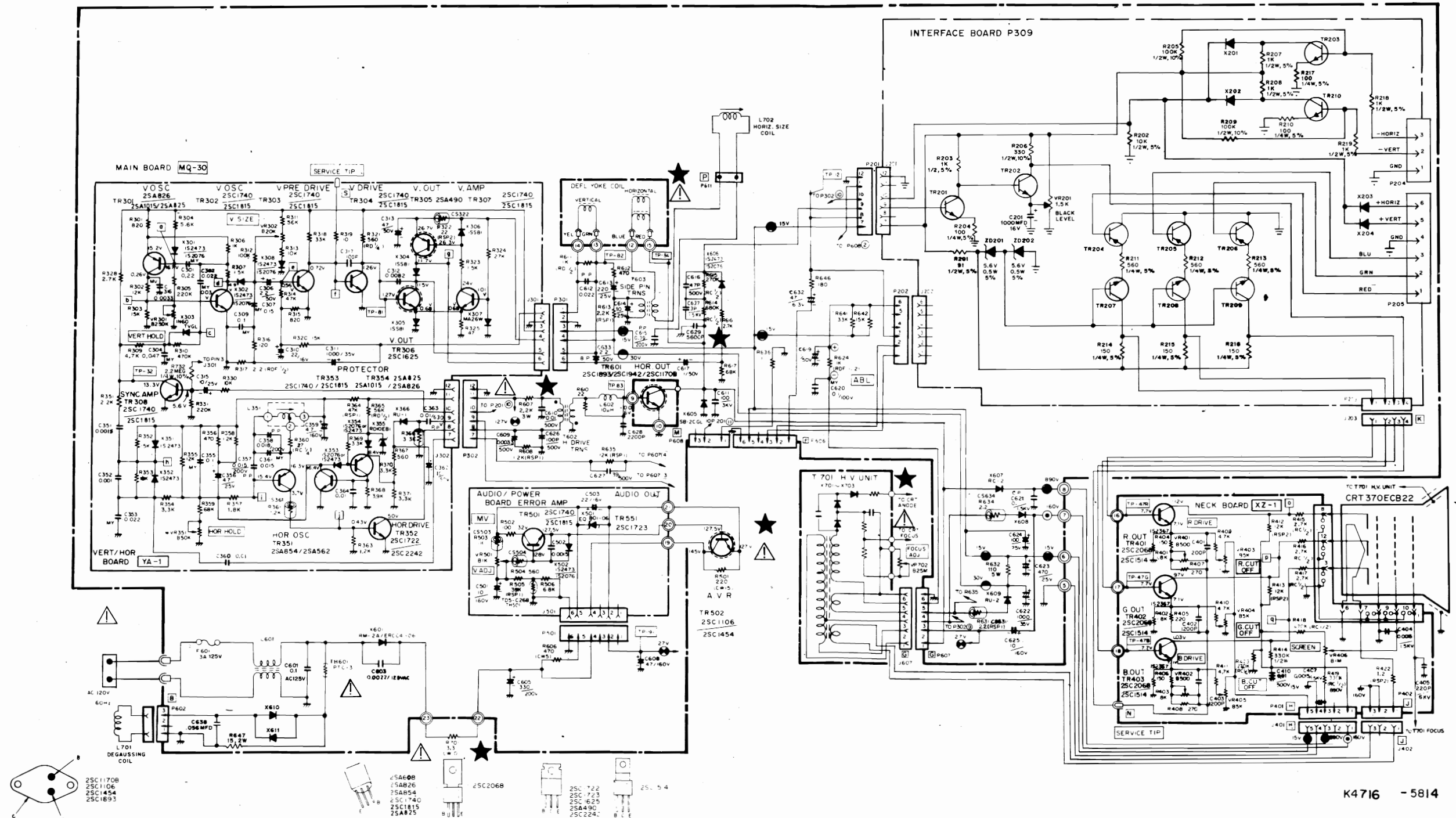

K4716 - 5814

M051-00087-A010